

RELINE™ RELINE™

Technique Guide



CONTENTS

Preface	1
Integrated Global Alignment Overview	2
Reline™ System Overview	3
Reline – Open Technique Guide	9
Reline – Open Advanced Applications	27
Reduction Screws	28
Hooks	29
Iliac Screws	30
Adjacent Segment Fixation	31
Vertebral Body Derotation	32
Osteotomies	34
Reline – MAS® Core Technique Guide	39
Reline – MAS Short Construct Technique Guide	73
Reline – MAS Reduction Screw Technique Guide	81
Implant Removal	88
Reline System	91
Reline System – Open	92
Reline System – MAS	114
Instructions for Use	126

PREFACE

Fellow Colleagues:

Alignment matters. Global spinal alignment has emerged over the past decade as a critical concept in understanding the impact of pathology and treatment in spinal fusion. Preservation and restoration of spinal alignment are based on a patient's individual spinopelvic parameters throughout the continuum of care. The Integrated Global Alignment (iGA™) platform allows surgeons to calculate, correct, and confirm through preoperative planning, intraoperative assessment, and postoperative confirmation.

At the onset of this endeavor, our goal was to develop a streamlined and universal portfolio of fixation systems within the iGA platform to stand as the centerpiece of our individual armamentariums. The Reline™ portfolio represents an evolution of posterior fixation technology designed to facilitate the preservation and restoration of patient alignment, while addressing a vast array of spinal pathologies from an open, MAS®, or hybrid approach.

We are confident that you will find the Reline portfolio supports a multitude of techniques for the treatment of even the most complex pathologies.

Cordially,

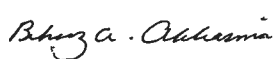

Behrooz A. Akbarnia, M.D.
Orthopaedic Surgeon
Clinical Professor
Department of
Orthopaedic Surgery
UC San Diego
President & Founder,
San Diego Spine Foundation
San Diego, CA
USA



Christopher R. Brown, M.D.
Orthopaedic Surgeon
Division of
Orthopaedic Surgery
Duke University
Medical Center
Durham, NC
USA



Vedat Deviren, M.D.
Professor
Clinical Orthopaedics
Orthopaedic Surgery
UCSF Spine Center
San Francisco, CA
USA



Paul A. Glazer, M.D.
Orthopaedic Surgeon
Spine Specialists of Boston
Boston, MA
USA

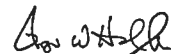

Regis W. Haid, M.D.
Neurosurgeon
Atlanta Brain and Spine Care
Atlanta, GA
USA



Prof. Dr. med. Henry Halm
Associate Professor
Head of The Department
of Spine Surgery and
Scoliosis Centre
Schön Klinik Neustadt
Neustadt in Holstein
Germany



Serena Hu, M.D.
Professor and Chief,
Spine Service
Department of
Orthopaedic Surgery
Stanford University
School of Medicine
Stanford, CA
USA



Kamal N. Ibrahim, M.D.,
F.R.C.S.(C), M.A.
Clinical Professor
Loyola University Chicago
DuPage Medical Group
Elmhurst, IL
USA



Tyler R. Koski, M.D.
Neurosurgeon
Associate Professor
Neurological Surgery
Northwestern University
Feinberg School of Medicine
Chicago, IL
USA



Mark D. Peterson, M.D.
Orthopaedic Surgeon
Southern Oregon Spine Care
Medford, OR
USA



Erik C. Spayde, M.D.
Orthopaedic Surgeon
Conejo Spine
Thousand Oaks, CA
USA

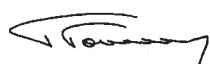

Antoine G. Tohmeh, M.D.
Orthopaedic Surgeon
Northwest Orthopaedic
Specialists
Spokane, WA
USA



Stewart Tucker,
MBBS, FRCS (Eng),
FRCS (Orth)
Orthopaedic Surgeon
The Wellington Hospital
London, England
UK



Juan Uribe, M.D.
Neurosurgeon
Associate Professor
Director of Spine Services
University of South Florida
Department of Neurosurgery
Tampa, FL
USA



Jim A. Youssef, M.D.
Orthopaedic Surgeon
Spine Colorado
Durango, CO
USA

INTEGRATED GLOBAL ALIGNMENT OVERVIEW



CALCULATE



ANTERIOR COLUMN

CORRECT

POSTERIOR COLUMN



CONFIRM

Integrated Global Alignment (iGA™) is a platform comprised of procedurally based technologies, designed to enhance clinical and economic outcomes by increasing the predictability of achieving global alignment in all spinal procedures. Integration across the surgical workflow allows the surgeon to confidently and reproducibly:

- **Calculate** alignment parameters with preoperative planning tools.
- **Correct** the anterior and posterior column with comprehensive procedural solutions from NuVasive® with the industry's only real-time intraoperative assessment.
- **Confirm** the restoration and preservation of global alignment postoperatively.

WHY ALIGNMENT MATTERS.

Current and emerging data illustrates a direct correlation between spinal alignment and long-term clinical outcomes.* Specific spinopelvic parameters, including the mismatch of the pelvic incidence (PI) and lumbar lordosis (LL), are key predictors in determining successful patient outcomes in all spinal procedures from single- to multi-level pathologies. NuVasive is committed to a global approach for assessing, preserving, and restoring spinal alignment in an effort to promote surgical efficiencies, lasting patient outcomes, and improved quality of life. **Alignment Matters.**

*Terran J, Schwab F, Shaffrey CI, et al. The SRS-Schwab adult spinal deformity classification: assessment and clinical correlations based on a prospective operative and nonoperative cohort. *Neurosurg* 2013;73(4): 559-68.

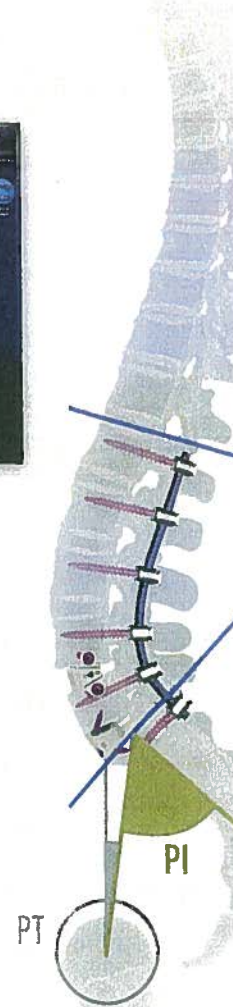
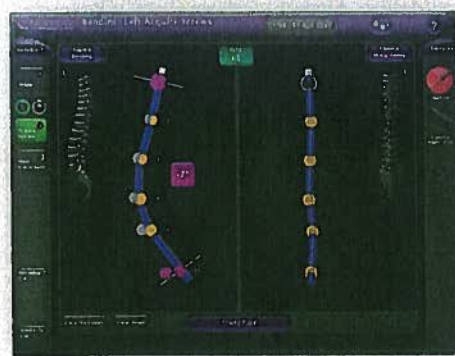

RELINE

NUVALINE®

XLIF ACR

NUVAMAP®

ALIF ACR

NUVAMAP®

BENDINI

NUVASIVE

RELINE™ SYSTEM OVERVIEW

PEDICLE SCREW PORTFOLIO



- Reline pedicle screws accept 5.0, 5.5, or 6.0mm rods in titanium (Ti6Al4V) or cobalt chrome (CoCr).
- The low-profile tulip design features:
 - Helical Flange® Locking Technology to reduce head splay and minimize cross-threading.
 - Universal instrument engagement features for seamless integration between MAS® and traditional open surgical approaches.
- Screw shanks feature a double lead thread form for efficient screw insertion and are available in both solid and cannulated designs. Screw shanks and load rings are color-coded to the shank diameter as outlined in Table 1 (e.g., a 6.5mm screw has a magenta shank and load ring).

TABLE 1: Shank/Load Ring Colors Correspond to Screw Diameter

4.0mm	4.5mm	5.0mm	5.5mm	6.5mm	7.5mm	8.5mm	9.5mm
<i>Bronze</i>	<i>Green</i>	<i>Light Blue</i>	<i>Gold</i>	<i>Magenta</i>	<i>Dark Blue</i>	<i>Purple</i>	<i>Light Green</i>

POLYAXIAL	POLYAXIAL REDUCTION	MONOAXIAL	UNIPLANAR	UNIPLANAR REDUCTION	PROVISIONAL LOCKING SCREW	OPEN ILIAC	CLOSED ILIAC	MAS REDUCTION
Simplified rod seating in solid and cannulated shanks	Extended tulip for up to 15mm of instrument-free reduction	Low-profile rigid fixation	Angulation restricted to the sagittal plane for axial rotational correction while preserving sagittal alignment	Axial rotational correction with up to 15mm of instrument-free reduction	Polyaxial angulation locks into a fixed orientation providing the flexibility of a polyaxial screw with the corrective capability of a fixed screw	Simplified rod seating for iliac fixation	Low-profile tulip reduces screw prominence in iliac fixation	Integrated reduction extensions for up to 15mm of instrument-free reduction through a minimal skin incision

RELINE™ SYSTEM OVERVIEW

LOCK SCREW COMPATIBILITY

The Reline portfolio includes three types of lock screws, all of which can be used with 5.0, 5.5, or 6.0mm rods; however, their suggested pairings are displayed in Table 2.

- **5.5mm cannulated lock screw** (dark blue bottom, silver top): for open tulips and intended for use with rod diameters 5.0-5.5mm. A 5.5mm lock screw will sit flush with the top of the tulip when final tightened on a 5.5mm rod, and 0.5mm proud when final tightened on a 6.0mm rod.
- **6.0mm cannulated lock screw** (teal bottom, silver top): for open tulips and intended for use with a 6.0mm rod. The 6.0mm lock screw will sit flush with the top of the tulip when final tightened on a 6.0mm rod, and will sit 0.5mm below the tulip if final tightened on a 5.5mm rod.
- **Closed, noncannulated lock screw** (light blue): for closed tulips and compatible with 5.0-6.0mm rod diameters.

Reline 5.5 or 6.0mm lock screws must be inserted silver side up into the tulip.

TABLE 2: Lock Screw Compatibility Chart

LOCK SCREW	 5.5mm	 6.0mm	 Closed
ROD SIZE	5.0, 5.5mm	6.0mm	5.0-6.0mm
TULIP	Open	Open	Closed
LOCKING MECHANISM	Helical Flange®	Helical Flange	Metric Thread

ROD TECHNOLOGY — VERSATILITY IN CONSTRUCT STRENGTH AND STIFFNESS

The Reline portfolio includes three rod diameters (5.0, 5.5, and 6.0mm) offered in titanium (Ti6Al4V) or cobalt chrome (CoCr), which enable surgeons to optimize the construct stiffness and strength to the individual needs of the patient.

- **Titanium** rods are available in prebent and straight options. They are color-coded by diameter and feature solid lines for proper sagittal orientation.
- **Cobalt chrome** rods feature a textured surface for improved grip strength within instruments and implants. All CoCr rods are marked with a dashed line for proper sagittal orientation.
- **MAS®** rods feature a bullet tip to ease rod passage through tissue, and an inserter engagement feature for controlled rod delivery.
- **Thoracolumbar (TL)** rods incorporate both pre-bent kyphotic and lordotic bends designed to reduce intraoperative rod contouring time and minimize rod notching.
- **Tapered diameter** rods offer differential rod stiffness along the length of the construct, providing the rigidity required for lumbar stabilization with a less rigid landing in the thoracic region. Options include rods that taper from 6.0 to 5.0mm or 5.5 to 5.0mm in Ti and CoCr.

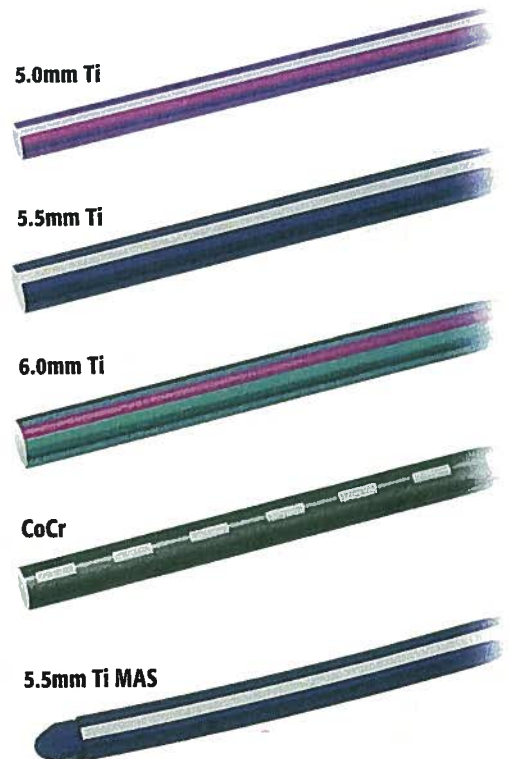

RELINE™ SYSTEM OVERVIEW

ADJACENT SEGMENT FIXATION (ASF) PORTFOLIO

- Reline rod-rod connectors feature rod slots designed to accept either 5.0-6.0mm (silver rod slot) or 6.35mm (green rod slot) diameter rods to accommodate the range of rods typically seen in pedicle screw constructs.
- With a variety of implant options, the Reline ASF system has the versatility to link onto existing constructs with minimal tissue disruption, and accommodate multiple surgical approaches to revision surgery.



CROSS CONNECTOR PORTFOLIO

- The low-profile cross connectors feature a T20 cam style locking mechanism designed for specific rod diameters: 5.5mm (dark blue) or 6.0mm (teal).
- Fixed and adjustable cross connectors use the same inserters and drivers.

Low-Profile Fixed

- Size offering: 20-35mm in 2.5mm increments
- Rod compatibility: 5.5mm, 6.0mm



Low-Profile Adjustable

- Size offering: ranges span from 30mm up to 65mm
- Rod compatibility: 5.5mm, 6.0mm, 5.5/6.0mm hybrid



HOOK PORTFOLIO FOR VARIABLE ANATOMY

- The Reline hook portfolio offers a variety of anatomically designed blades in a range of throat diameters (color-coded below) to accommodate anatomic variability.
- Multiple hook site preparation tools and inserter options enable surgeons to place hooks according to their preferred technique.



LAMINA

PEDICLE

TRANSVERSE
PROCESS

DOWN ANGLED

UP ANGLED

ANGLED

OFFSET



RELINE™ SYSTEM OVERVIEW

INTEGRATED OPERATIVE SOLUTIONS

NuvaPlanning™

The restoration and preservation of patient alignment begins with calculating measurements and developing a surgical plan. The NuvaPlanning portfolio is a platform composed of three software solutions designed to intuitively navigate a healthcare professional through obtaining alignment measurements and developing surgical plans across the surgical workflow, calculating and confirming preoperatively, intraoperatively, and postoperatively in order to restore and preserve patient alignment.

NUVALINE®

NuvaLine™ is a simple software application for tablet and mobile devices, designed to provide quick, on-the-go measurements to determine and evaluate alignment goals and objectives.

NUVAMAP®

NuvaMap™ powered by Surgimap, is a comprehensive software solution designed to assist healthcare professionals in viewing, storing, and measuring images, as well as simulating cases for interventional procedures, and sharing case plans.

NUVAMAP® O.R.

NuvaMap O.R. is an NVM5® software application which enables the industry's only real-time intraoperative assessment of various patient anatomical parameters and alignment values through the use of fluoroscopy.

NVM5: Procedurally Integrated Neuromonitoring

Comprehensive suite of intraoperative neuromonitoring modalities that promote positive neurological outcomes.

Real-time information on nerve proximity when placing screws with **Dynamic EMG**.

Continuous monitoring for mechanical disturbances to nerve root structures with **Free Run EMG**.

Combined **MEP** and **SSEP** monitoring for a reliable method of monitoring spinal cord function with greater sensitivity and predictability than single-modality techniques.¹

¹Pelosi L, Lamb J, Grevitt M, et al. Combined monitoring of motor and somatosensory evoked potentials in orthopaedic spinal surgery. *J Clin Neurophys* 2002;113(7):1082-91.

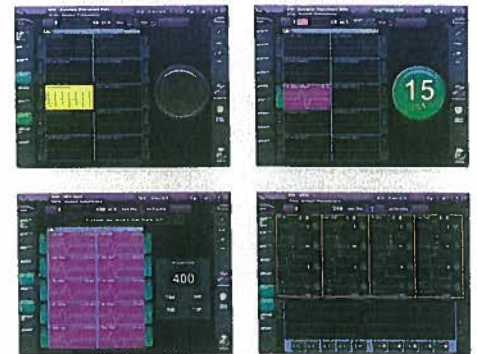

Bendini® Computer-Assisted Rod Bending Technology

The Bendini spinal rod bending system expedites manual rod manipulation via computer-assisted bend instructions. This benefits both you and your patients with:

Decreased O.R. Time

Predictable, reproducible rod bending helps surgeons create rods which often require a single pass.²

Restored Alignment

Surgeon-driven menus enable rapid intraoperative alignment assessment and rod customization. Coronal and sagittal design tools help guide surgeons to achieve alignment goals prior to exiting the O.R.

Minimized Screw Strain

Patient-specific rods are designed to minimize forces on the screw-bone interface and minimize unnecessary preloading of the construct.³

²Wupperman RM, Isaacs RE, Taylor WR. The Bendini spinal rod bending system for long percutaneous pedicle screw constructs: cadaveric utility study and early clinical experience. Society of Lateral Access Surgery (SOLAS) 2013 Annual Meeting. San Diego, CA, USA.

³Tohmeh AC, Isaacs RE, Dooley ZA, et al. Long construct pedicle screw reduction and residual forces are decreased using a computer-assisted rod bending system. *J Spine Neurosurg* 2014;S2.



RELINE™ —
OPEN TECHNIQUE
GUIDE

RELINE™ – OPEN TECHNIQUE GUIDE

OPEN TECHNIQUE GUIDE | OPEN ADVANCED APPLICATIONS | REDUCTION SCREWS | HOOKS | ILIAC SCREWS | ADJACENT SEGMENT FIXATION | VERTEBRAL BODY DEROTATION | OSTEOTOMIES

RELINE CORE TRAYS

- Reline Core Implant Tray
- Reline Core Instrument Tray 1
- Reline Core Instrument Tray 2

RELINE OPTIONAL TRAYS

Refer to the back of this technique guide for a complete list of trays and implant sizes available.

- C-arm Fluoroscope
- Radiolucent Surgical Table
- NVM5® System

For a complete list of intended uses, indications, device description, contraindications, warnings, and precautions, please refer to the Instructions for Use (IFU) in the back of this technique guide.

PATIENT POSITIONING AND O.R. SETUP

Place the patient on the operating table in a prone position. Prepare and drape in a conventional manner. The fluoroscope should have easy access to the surgical field for both A/P and lateral views. Uniplanar or biplanar fluoroscopy may be used. Fluoroscopic monitors and the NVM5 unit should be placed in clear view (Fig. 1). It is preferable to place the NVM5 unit at the foot of the bed.

Place the EMG/MEP neuromonitoring electrodes on the patient. If SSEP monitoring is planned for the surgery, place these electrodes as well.

Once electrodes are properly placed, execute a Twitch Test to determine if neuromuscular blockades are out of the patient's system and if effective neuromonitoring can be accomplished.

NUVAMAP™/NUVALINE™

After using NuvaMap or NuvaLine software to preoperatively measure spinopelvic parameters, input values into NuvaMap O.R. to intraoperatively assess sagittal alignment (PI-LL) in real-time on imported fluoro images throughout key points of the procedure (Fig. 2).

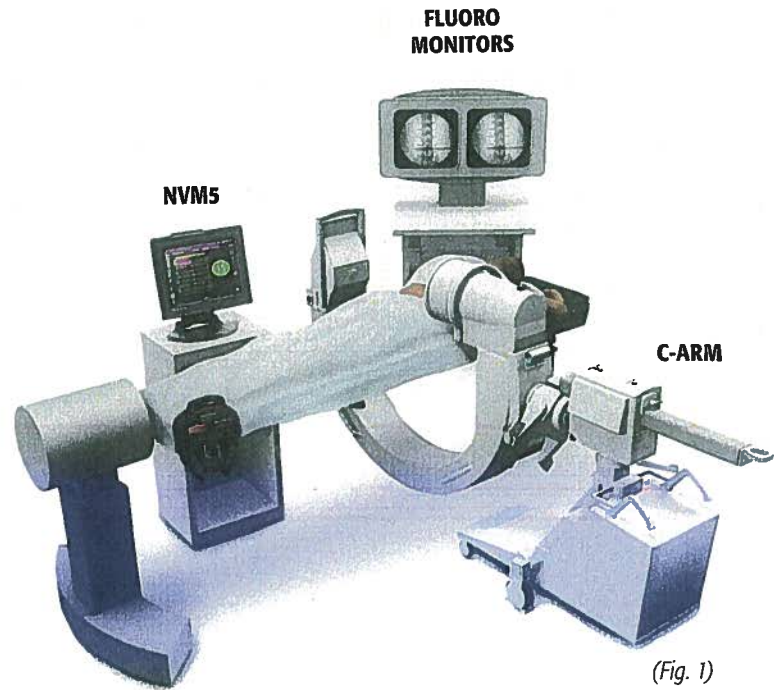

(Fig. 1)

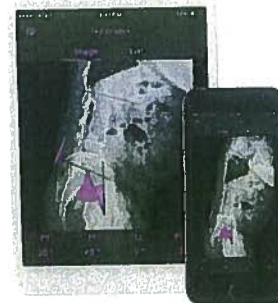

NUVALINE™



NUVAMAP™

NUVAMAP™ O.R.

(Fig. 2)

RELINE™ – OPEN TECHNIQUE GUIDE

OPEN TECHNIQUE GUIDE | OPEN ADVANCED APPLICATIONS | REDUCTION SCREWS | HOOKS | ILIAC SCREWS | ADJACENT SEGMENT FIXATION | VERTEBRAL BODY DEROTATION | OSTEOTOMIES

**STEP 1:
PEDICLE PREPARATION**

1. Locate the desired entry point into the pedicle, and perforate the cortex with a high-speed burr. Create a pilot hole by passing a Gearshift Probe through the pedicle and into the vertebral body (Fig. 3).

Tip: Gearshift Probes, Taps, and Pedicle Probes are marked with a solid band between 40mm and 50mm to help visualize depth once in bone.

2. Inspect the pilot hole for perforations with the Dual-ended Ball Tip Pedicle Probe by palpating the pedicle wall on all sides (Fig. 4).

3. Reline screws are self-tapping, and may be inserted at this point.

4. If tapping is preferred, select the preferred Ratcheting Handle, and attach to an appropriately sized Tap. Set the ratchet to the preferred drive position and tap through the ratchet to the preferred drive position and tap through the pedicle into the vertebral body, using the markings on the shaft and fluoroscopy to monitor depth (Fig. 5).

Tip: Taps are sized line-to-line as marked, and the threads are 40mm in length.

5. Prior to screw insertion, inspect the pilot hole again for perforations, using the Dual-ended Ball Tip Pedicle Probe.



(Fig. 3)

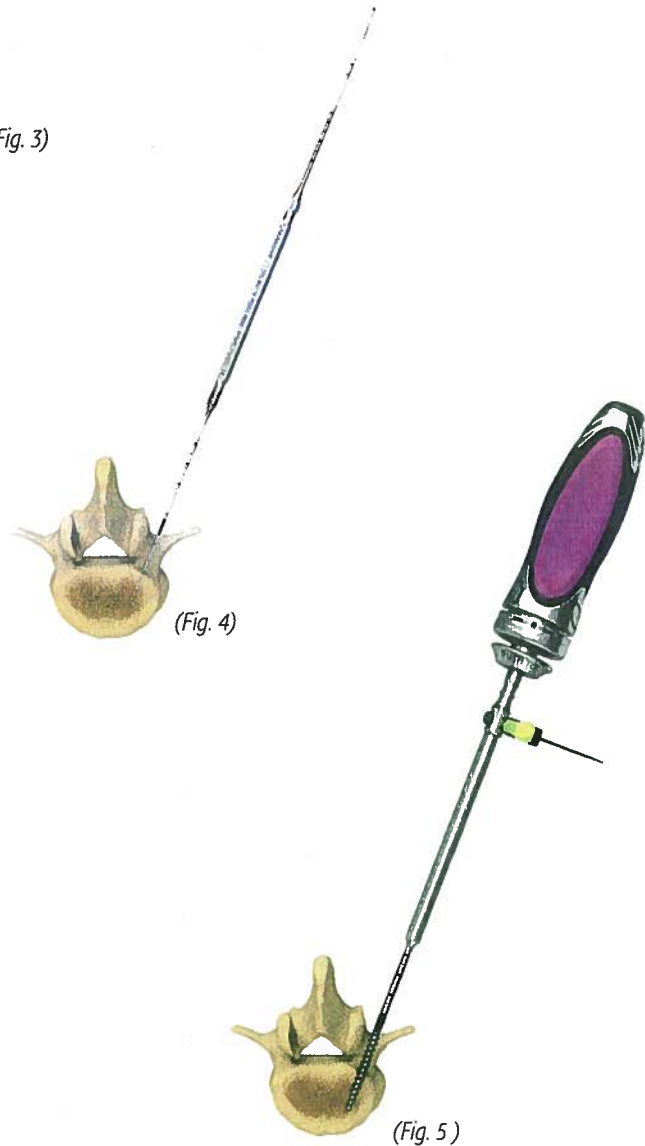

(Fig. 4)

(Fig. 5)

NVM5*



Use NVM5 to monitor pedicle integrity during pedicle preparation. Insulate a Gearshift Probe or Tap from surrounding tissue with the insulating sheath. Attach the Dynamic Stimulation Clip to the shaft of the instrument, and stimulate using the Dynamic EMC modality.

RELINE™ – OPEN TECHNIQUE GUIDE

OPEN TECHNIQUE GUIDE | OPEN ADVANCED APPLICATIONS | REDUCTION SCREWS | HOOKS | ILIAC SCREWS | ADJACENT SEGMENT FIXATION | VERTEBRAL BODY DEROTATION | OSTEDOTOMIES

STEP 2: SCREW INSERTION

1. Once the pedicle has been prepared, select the preferred screw type and matching screwdriver (Fig. 6). Attach the ratcheting handle of choice to the screwdriver.
2. The Polyaxial Screwdriver can be adjusted for compatibility with polyaxial screws or polyaxial reduction screws by depressing the gold button and translating the inner shaft.
 - For polyaxial screws, depress the gold button on the silver knob and push the outer shaft forward toward the distal tip until it stops (Fig. 7).
 - For polyaxial reduction screws, depress the gold button on the silver knob and pull the outer shaft backward toward the handle until it stops. In this position, the NVM5® Dynamic Stimulation Clip ring is just below the "Load" lasermarking (Figs. 8, 8a).

Tip: This position can also be used to simplify insertion of the driver into all screws prior to thread engagement.

3. To load the screwdriver, insert the distal drive feature into the shank of the screw and secure by turning the silver knob clockwise. Verify that the screw and screwdriver interface is rigid and the shank is aligned straight.
4. Introduce the screw into the pilot hole and advance until the desired depth is reached (Fig. 9). The screwdriver's sleeve is designed to rotate freely, allowing the instrument to be firmly grasped throughout insertion without unthreading from the screw.
5. To release the screwdriver, turn the silver knob counterclockwise until the outer sleeve is fully unthreaded from the tulip, and remove from the screw.
6. For polyaxial screws, ensure the screw tulip is free from tissue or bony impedance and retains its full polyaxial motion. If adjustment to screw depth is required, the Screw Adjuster may be used. The Head Adjuster may be used to adjust the cephalad/caudal or medial/lateral orientation of the tulip prior to rod insertion.
7. Use NVM5 Stimulation Probe to test screws once inserted into bone (Fig. 10).

POLYAXIAL



(Fig. 7)

MONOAXIAL



(Fig. 8)

REDUCTION



(Fig. 8a)

CLOSED ILIAC



(Fig. 6)

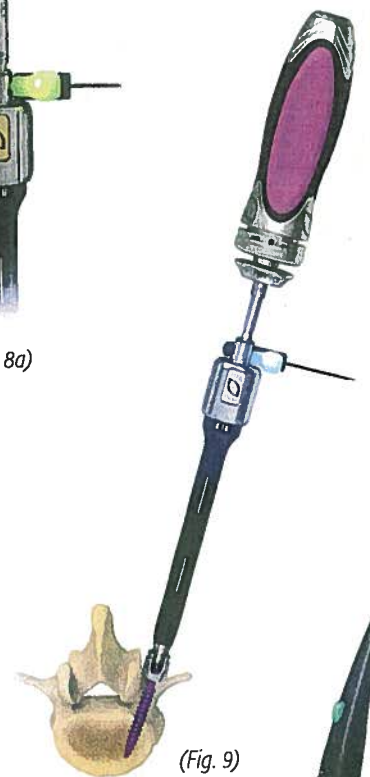

(Fig. 9)



(Fig. 10)

RELINE™ – OPEN TECHNIQUE GUIDE

OPEN TECHNIQUE GUIDE | OPEN ADVANCED APPLICATIONS | REDUCTION SCREWS | HOOKS | ILIAC SCREWS | ADJACENT SEGMENT FIXATION | VERTEBRAL BODY DEROTATION | OSTEOTOMIES

**STEP 3:
ROD CONTOURING**

Once all screws are in position, measure the length of the construct and bend the appropriately sized rod using the preferred technique.

1. Use the French Bender to contour 5.0-6.0mm rods at multiple points using the dial to select the bend radii: small, medium, or large (Fig. 11).

Tip: Rods feature longitudinal lines along the sagittal plane to provide an alignment reference when contouring the rod.

2. To achieve tight radii or larger radii bends, place the rod into the corresponding diameter hole of the Plate Bender and leverage the benders against each other to achieve the desired contour. For additional stability, one Plate Bender can be placed within slots adjacent to the Rod Cutter (Fig. 12).

3. The NVM5® Bendini® system may be used at this step for computer-assisted rod bending.

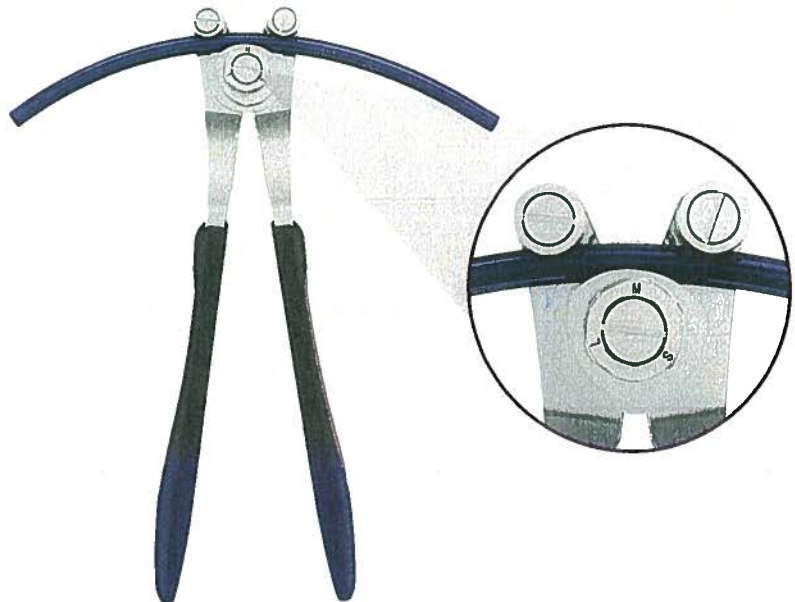

(Fig. 11)

BENDINI

The Bendini computer-assisted spinal rod bending system is used to create custom rods that are bent specifically to implant locations. Or additional corrective maneuvers can be achieved using the software to help improve the patient's alignment. Refer to the Bendini Surgical Technique for more information about how to use the technology.



(Fig. 12)

RELINE™ — OPEN TECHNIQUE GUIDE

OPEN TECHNIQUE GUIDE | OPEN ADVANCED APPLICATIONS | REDUCTION SCREWS | HOOKS | ILIAC SCREWS | ADJACENT SEGMENT FIXATION | VERTEBRAL BODY DEROTATION | OSTEO TOMIES

STEP 4: ROD & LOCK SCREW INSERTION

After cutting the rod to length and contouring, place the rod into the implants and insert lock screws to provisionally secure the rod.

1. The Rod Holder may be used to assist in placing the rod (Fig. 13). Use the longitudinal lines to ensure the rod is placed in proper sagittal alignment. To release the rod, depress the button at the center of the proximal ratchet.
2. The Multi-load Lock Screw Starter can be used to deliver up to eight lock screws when no reduction is required (Fig. 14).
 - Turn the gray central sleeve counterclockwise to fully retract the distal sleeve.
 - Insert the distal end into the lock screw (5.5 or 6.0mm, cannulated only), ensuring the silver side of the lock screw is facing up.
 - Once the lock screws have been loaded, turn the central sleeve clockwise to compress the lock screws together. Do not hold onto the central sleeve during lock screw delivery, as this will cause the distal sleeve to retract, preventing adequate compression of the lock screws.
 - After delivery of each lock screw, rotate the central sleeve clockwise until resistance is felt prior to delivering the next lock screw.

Tip: The lock screws on the Multi-load Lock Screw Starter must be compressed by the central sleeve after delivery of each lock screw to ensure proper engagement into the tulip.

3. If reduction is required, use the Lock Screw Starter to load a single lock screw and deliver down the reducer of choice.

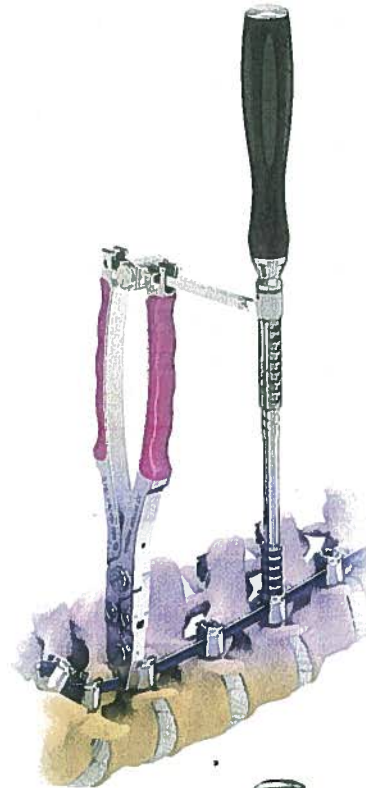

(Fig. 13)

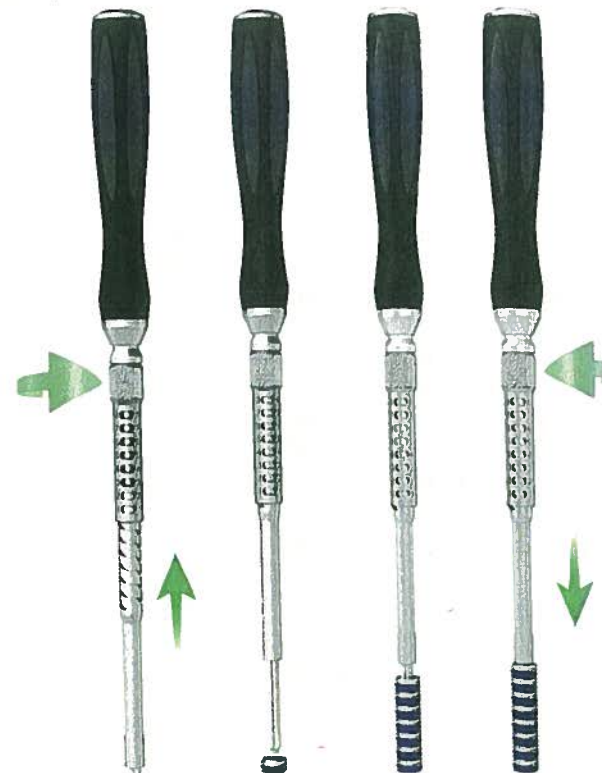

(Fig. 14)

RELINE™ — OPEN TECHNIQUE GUIDE

OPEN TECHNIQUE GUIDE | OPEN ADVANCED APPLICATIONS | REDUCTION SCREWS | HOOKS | ILIAC SCREWS | ADJACENT SEGMENT FIXATION | VERTEBRAL BODY DEROTATION | OSTEOTOMIES

STEP 4:
ROD & LOCK SCREW INSERTION (CONT.)

The Rod Gripper can be used for complex rod manipulation or rod rotation maneuvers.

1. To attach the Rod Gripper to a rod, ensure the tips of the Rod Gripper are open by depressing the ratchet release trigger. Place the Rod Gripper over the rod and compress the handle until rigidly fixed to the rod (*Fig. 15*).
2. If a rod rotation maneuver is required, ensure the lock screws are loose within the tulips prior to attaching the Rod Grippers. Two Rod Grippers should be used to rotate the rod in multiple steps, alternating releasing the Rod Grippers one at a time, until the desired coronal and sagittal profile is achieved. After the rod has been rotated into its final position, tighten the lock screws using the Lock Screw Starter and release the Rod Grippers from the rod.

Tip: Rods greater than 200mm feature a hex end for attaching a Rod Rotation Wrench.

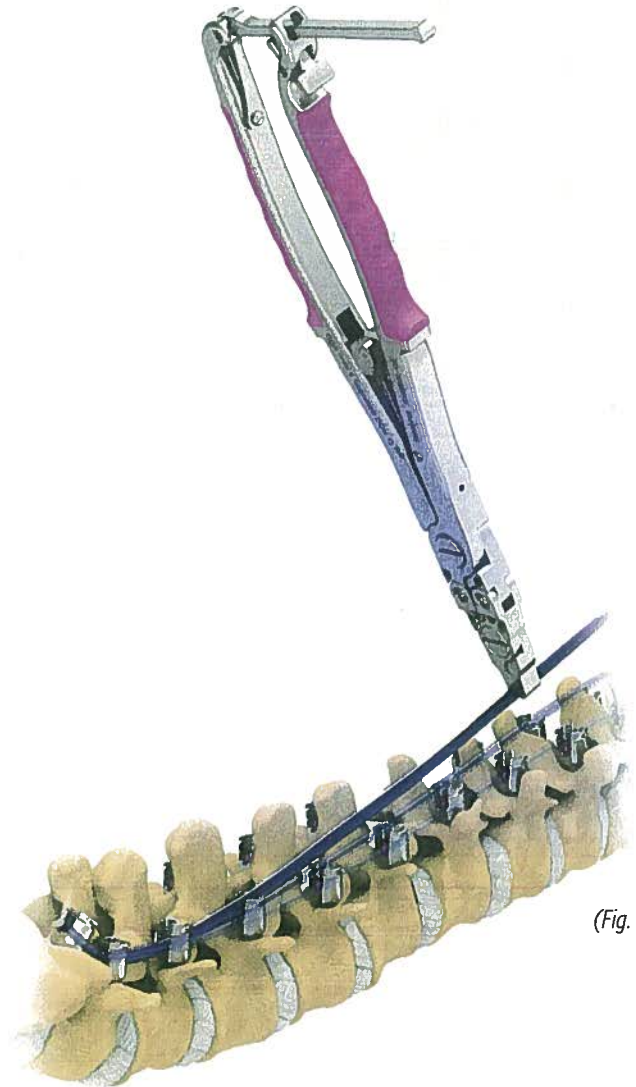

(Fig. 15)

RELINE™ – OPEN TECHNIQUE GUIDE

OPEN TECHNIQUE GUIDE | OPEN ADVANCED APPLICATIONS | REDUCTION SCREWS | HOOKS | ILIAC SCREWS | ADJACENT SEGMENT FIXATION | VERTEBRAL BODY DEROTATION | OSTEOTOMIES

STEP 5: ROD REDUCTION

Multiple options are available to achieve varying amounts of rod reduction.

Silencer Reducer

The Silencer Reducer should be used when large amounts of reduction (up to 45mm) are required.

1. Ensure the threaded reduction sleeve is retracted by turning it counterclockwise until sufficient space is available within the rod slot.
2. Capture the rod within the rod slot of the Silencer Reducer and align the distal tip to the tulip. Push down on the reducer to engage the tulip, and verify proper engagement by pulling up on the reducer. The Silencer Reducer arms provide audible and tactile feedback when properly engaged to the tulip.
3. Place the Reduction T-handle onto the threaded reduction sleeve and turn clockwise (Fig. 16) until the black line overlaps the proximal end of the reducer. If reducing over multiple levels, use the Reduction Bell Attachment on a Straight Ratcheting Handle to minimize interference with adjacent reducers.
4. Once reduction is achieved, insert the lock screw using the Lock Screw Starter, and remove the reducer by depressing the medial/lateral silver buttons and pulling up on the instrument (Fig. 17).

Tip: To ease removal of the reducer, turn the T-handle 1/4 turn counterclockwise after fully reducing the rod, and prior to lock screw delivery.

CAUTION

The Silencer Reducer is not compatible with polyaxial reduction screws or uniplanar reduction screws and may damage the implant if used.



RELINE™ – OPEN TECHNIQUE GUIDE

OPEN TECHNIQUE GUIDE | OPEN ADVANCED APPLICATIONS | REDUCTION SCREWS | HOOKS | ILIAC SCREWS | ADJACENT SEGMENT FIXATION | VERTEBRAL BODY DEROTATION | OSTEOTOMIES

**STEP 5:
ROD REDUCTION (CONT.)**

Matador Reducer

The Matador Reducer should be used when a small amount of reduction is needed (12mm), or a single-handed reduction option is preferred.

1. Align the handles of the reducer perpendicular to the rod and slide the distal tip over the screw head and push down until the reducer bottoms out (Fig. 18).
2. Slowly compress the handles to overcome the initial resistance – this first mechanism locks the reducer onto the tulip. Continue to squeeze the handles to reduce the rod (Fig. 19). The ratchet arm may be utilized to hold reduction.
3. Once the rod is fully reduced, a gold line will be visible above the outer silver shaft. Insert a lock screw using the Lock Screw Starter, release the instrument, and remove the instrument by releasing the ratchet.

Tip: The Matador Reducer can be used to reduce rods into polyaxial reduction screws or uniplanar reduction screws.



(Fig. 18)



(Fig. 19)

NVM5*



Monitor for nerve disturbances (EMG) and changes in spinal cord motor (MEP) and sensory (SSEP) baselines during rod reduction, in situ rod bending, compression/distraction, and final tightening.

RELINE™ – OPEN TECHNIQUE GUIDE

OPEN TECHNIQUE GUIDE | OPEN ADVANCED APPLICATIONS | REDUCTION SCREWS | HOOKS | ILIAC SCREWS | ADJACENT SEGMENT FIXATION | VERTEBRAL BODY DEROTATION | OSTEOTOMIES

STEP 5: ROD REDUCTION (CONT.)

Rocker

When a small amount of reduction (9mm) is required, the Rocker may be used to seat the rod.

1. With the Rocker in an upright position, align the Rocker pins to the circular divot features on the medial and lateral sides of the tulip (Fig. 20).
2. Squeeze the handles until the Rocker securely grasps the implant. The ratchet arm can be used to hold compression of the handles to maintain engagement to the tulip.
3. Rotate the Rocker downward to seat the keel onto the rod. Continue to rotate the Rocker until the rod is fully seated in the tulip.
4. Insert a lock screw using the Lock Screw Starter (Fig. 21), and then remove the instrument by releasing the ratchet.

Tip: The Rocker can be used to reduce rods into polyaxial reduction screws or uniplanar reduction screws.

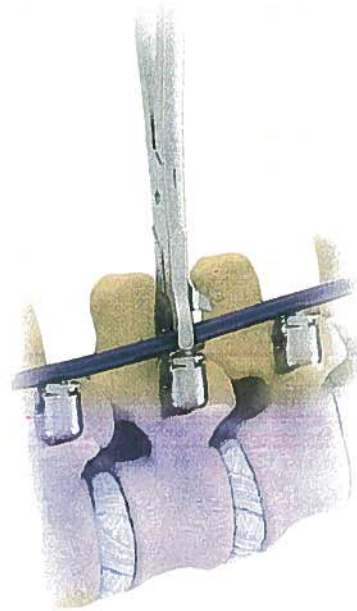

(Fig. 20)

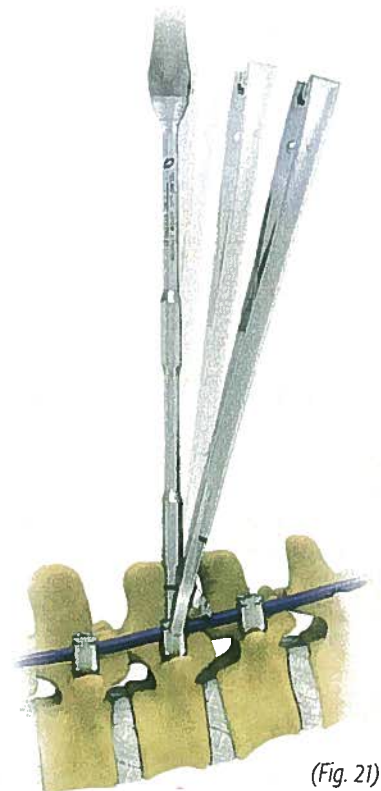

(Fig. 21)

RELINE™ — OPEN TECHNIQUE GUIDE

OPEN TECHNIQUE GUIDE | OPEN ADVANCED APPLICATIONS | REDUCTION SCREWS | HOOKS | ILIAC SCREWS | ADJACENT SEGMENT FIXATION | VERTEBRAL BODY DEROTATION | OSTEOTOMIES

**STEP 5:
ROD REDUCTION (CONT.)**

Gator Reducer

The Gator Reducer should be used when a large amount of reduction (35mm) is required, or when the rod is slightly offset medial or lateral from the screw.

1. Ensure the threaded reduction sleeve is retracted by turning it counterclockwise until sufficient space is available within the rod slot. Prior to engaging the tulip, verify that the silver arm is in the open position.
2. Capture the rod within the rod slot and align the distal tip to the tulip. Press the instrument down onto the tulip until it bottoms out, and squeeze the silver arm to engage the reducer onto the tulip (Fig. 22).
3. Place the Reduction T-handle onto the threaded reduction sleeve and turn clockwise (Fig. 23) until the black line overlaps the proximal end of the reducer.
4. Once reduction is achieved, insert the lock screw using the Lock Screw Starter (Fig. 24). Remove the reducer by opening the silver arm and pulling up on the instrument.

CAUTION

The Gator Reducer is not compatible with polyaxial reduction screws or uniplanar reduction screws and may damage the implant if used.



(Fig. 22)

(Fig. 23)



(Fig. 24)

RELINE™ – OPEN TECHNIQUE GUIDE

OPEN TECHNIQUE GUIDE | OPEN ADVANCED APPLICATIONS | REDUCTION SCREWS | HOOKS | ILIAC SCREWS | ADJACENT SEGMENT FIXATION | VERTEBRAL BODY DEROTATION | OSTEOTOMIES

**STEP 6:
IN SITU ROD BENDING**

In situ rod benders may be used for correction in the sagittal or coronal planes.

1. For sagittal correction, slide either the angled or straight ends of the In situ Sagittal Benders around the rod so that the rod sits flush within the rod slot. Compress the sagittal benders toward each other to achieve lordosis, or bend away from each other to produce kyphosis (*Fig. 25*).
2. To achieve coronal plane correction, place the right and left In situ Coronal Benders over the rod until the slots sit flush. Align the ridges at the 90° bends and compress the arms of the coronal benders toward each other (*Fig. 26*).
3. If bending over multiple levels, insert the pins of the Coronal Bender Extension Link into the benders, ensuring the retention clips are fully engaged and the pins sit flush on the bender (*Fig. 27*).



(Fig. 25)



(Fig. 26)

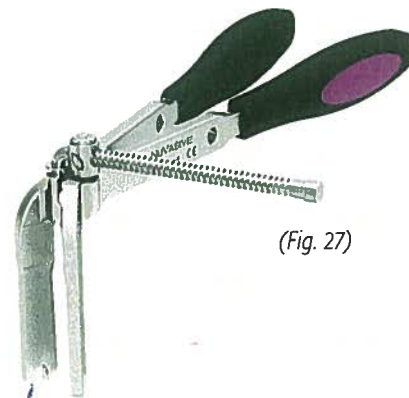

(Fig. 27)

RELINE™ – OPEN TECHNIQUE GUIDE

OPEN TECHNIQUE GUIDE | OPEN ADVANCED APPLICATIONS | REDUCTION SCREWS | HOOKS | ILIAC SCREWS | ADJACENT SEGMENT FIXATION | VERTEBRAL BODY DEROTATION | OSTEOTOMIES

**STEP 7:
COMPRESSION AND DISTRACTION**

If compression or distraction is desired, provisionally tighten a lock screw on one side of the motion segment, leaving the adjacent lock screw loose to allow movement along the rod.

1. Choose the Hinged Compressor (Fig. 28) or Distractor (Fig. 29), and place over the rod, against the tulip heads of the targeted screws. A Parallel Compressor is also available (Fig. 30).
2. With the instrument properly engaged, deliver the desired level of compression or distraction. Provisionally tighten the loose lock screw to hold the construct in position prior to final tightening.

Tip: It is not recommended to final tighten the lock screw while it is under the force of compression or distraction.

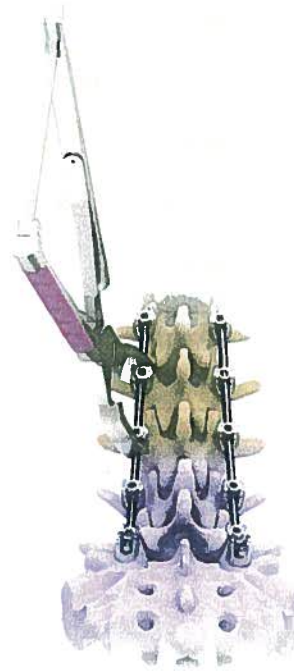

(Fig. 28)

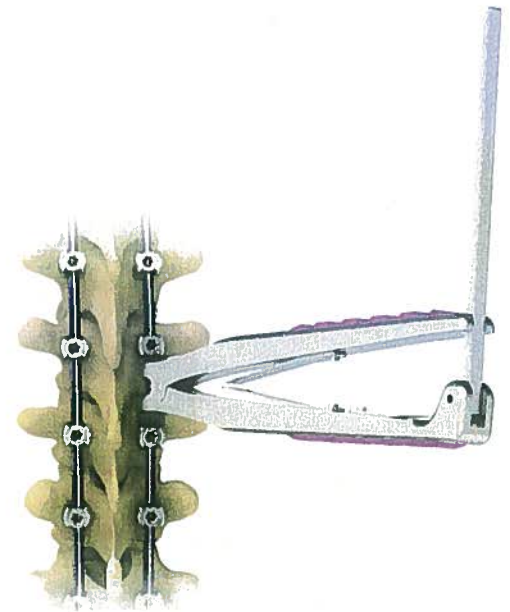

(Fig. 29)

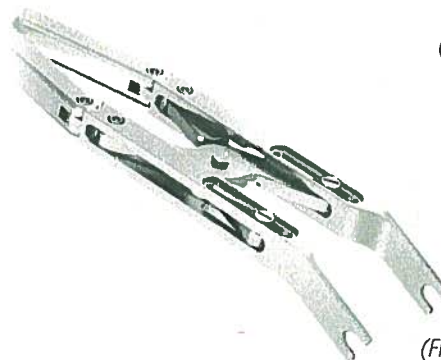

(Fig. 30)

RELINE™ – OPEN TECHNIQUE GUIDE

OPEN TECHNIQUE GUIDE | OPEN ADVANCED APPLICATIONS | REDUCTION SCREWS | HOOKS | ILIAC SCREWS | ADJACENT SEGMENT FIXATION | VERTEBRAL BODY DEROTATION | OSTEOTOMIES

STEP 8: FINAL TIGHTENING

All lock screws must be tightened to a torque of 90 in-lbs to effect a secure construct.

Tip: The Open Screw Counter-torque handle position can be adjusted in 45° increments by depressing the button at the distal end of the handle and rotating it (Fig. 31).

Attach the Torque T-handle to the Final Lock Screw Driver. Slide the Counter-torque over the tulip until the instrument bottoms out. Insert the Final Lock Screw Driver through the Counter-torque and seat securely into the lock screw. Turn the Torque T-handle clockwise until the breakaway torque is reached (Fig. 32). Repeat on each screw.

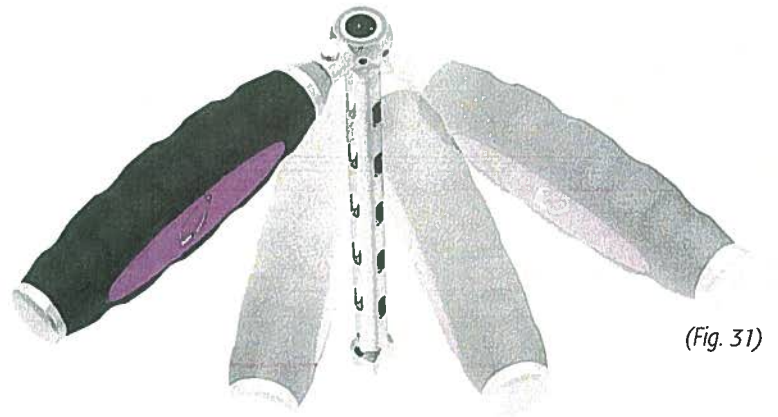

(Fig. 31)



(Fig. 32)

RELINE™ — OPEN TECHNIQUE GUIDE

OPEN TECHNIQUE GUIDE | OPEN ADVANCED APPLICATIONS | REDUCTION SCREWS | HOOKS | ILIAC SCREWS | ADJACENT SEGMENT FIXATION | VERTEBRAL BODY DEROTATION | OSTEOTOMIES

**STEP 9:
CROSS CONNECTORS**

Two cross connector options are available in the Reline portfolio to provide torsional stability to the construct. The low-profile adjustable cross connector and fixed cross connector both feature the same locking cam design instrument engagement features, and they use the same driver and Torque T-handle.

Prior to selecting the desired cross connector, measure the distance between the rods using the Cross Connector Measurement Guide (Fig. 33) to determine the correct length.

Low-Profile Adjustable Cross Connector

1. Align the Cross Connector Holder with the silver line on the end of the connector, and close the handles to engage the slots on each side (Fig. 34).
2. Place each end of the connector flush onto the rod.
3. Attach the Cross Connector 40 in-lb Torque T-handle to the Cross Connector Driver. Insert the driver into the distal barrel of the Cross Connector Holder, ensuring that it seats properly within the cam drive (Fig. 35). Rotate the handle until the breakaway torque is reached to lock the cam into the final position.
4. Verify the cam is locked by ensuring the wide arc of the cam drive feature aligns with the silver arc on the connector body (Fig. 36).
5. Once both sides of the cross connector are tightened, place the Low-Profile Adjustable Cross Connector Counter-torque over the center clamp and proceed with final tightening the center lock nut until the breakaway torque is reached (Fig. 37).



(Fig. 33)



(Fig. 34)



(Fig. 35)



(Fig. 37)



(Fig. 36)

RELINE™ – OPEN TECHNIQUE GUIDE

OPEN TECHNIQUE GUIDE | OPEN ADVANCED APPLICATIONS | REDUCTION SCREWS | HOOKS | ILIAC SCREWS | ADJACENT SEGMENT FIXATION | VERTEBRAL BODY DEROTATION | OSTEOTOMIES

STEP 9: CROSS CONNECTORS (CONT.)

Fixed Cross Connector

1. When using fixed cross connectors, the Fixed Cross Connector Benders may be utilized to make fine adjustments to the length by changing the curvature (Fig. 38) or altering the orientation of the rod slots to accommodate nonparallel rods (Fig. 39).
2. After placing the fixed cross connector into the appropriate slot of the Fixed Cross Connector Benders, slide the thumb piece toward the connector to secure it into position. Compress the benders toward each other to achieve the desired bend.
3. Align the Cross Connector Holder with the silver line on the end of the connector and close the handles to engage the slots on each side.
4. Place each end of the connector flush onto the rod.
5. Attach the Cross Connector Torque T-handle to the Cross Connector Cam Driver. Insert the Cross Connector Cam Driver into the distal barrel of the Cross Connector Cam Holder, and rotate the cam above each rod 180° (or until the 40 in-lb breakaway torque is reached) to lock the cam (Fig. 40).
6. Verify the cam is locked by ensuring the wide arc of the cam drive feature aligns with the silver arc on the connector body (Fig. 41).

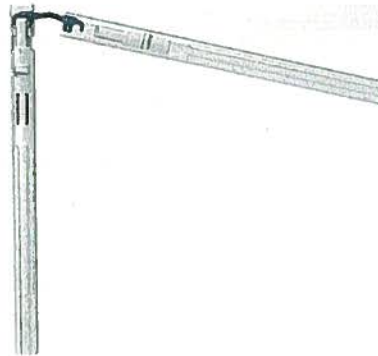

(Fig. 38)

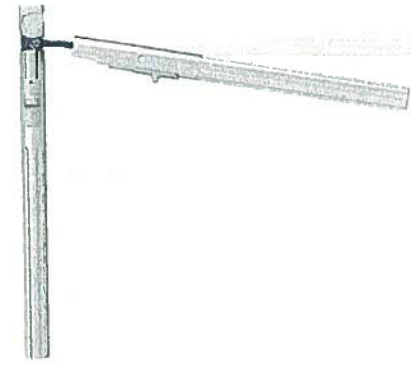

(Fig. 39)



(Fig. 40)



(Fig. 41)

OPTIONAL

Utilize NuvaMap™ O.R. to assess the lumbar lordosis (LL) achieved and its effect on sagittal alignment (PI-LL) in real-time after final rod placement and prior to closing (Fig. 42).

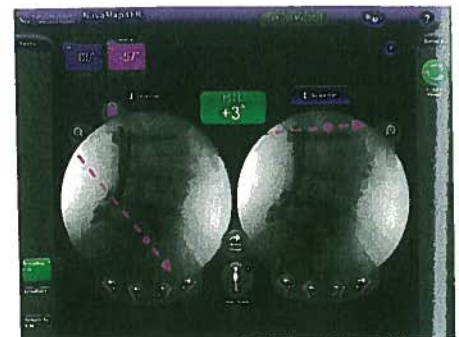

(Fig. 42)

**RELINE™ —
OPEN ADVANCED
APPLICATIONS**

RELINE™ – OPEN ADVANCED APPLICATIONS

OPEN TECHNIQUE GUIDE | OPEN ADVANCED APPLICATIONS | REDUCTION SCREWS | HOOKS | ILIAC SCREWS | ADJACENT SEGMENT FIXATION | VERTEBRAL BODY DEROTATION | OSTEOTOMIES

REDUCTION SCREWS

Reduction screws provide an alternative, low-profile rod reduction method.

1. Follow the Pedicle Preparation and Screw Insertion steps on pages 11-12 of the Open Technique Guide.
2. With the reduction screws and rod in place, slide the Reduction Screw Counter-torque over the screw head until it seats flush on the rod (Fig. 1).
3. Using the Lock Screw Starter, reduce the rod by threading a lock screw down the extended tulip. Be sure to apply downward force on the Counter-torque so the slot remains fully seated on the rod during reduction. The rod is fully reduced when the top of the lock screw sits below the recessed ridge at the base of the extended tulip.
4. With the rod fully reduced and the Counter-torque seated flush on the rod, slide the Reduction Screw Break-off Tool over an extended tulip with the thumb piece facing inward toward the rod slot. Rock the Break-off Tool in a medial/lateral direction until it breaks free from the screw head (Fig. 2). Repeat this process on the opposite Reduction Extension.

Note: The Break-off Tool can hold up to four Reduction Extensions. To expel the Reduction Extensions from the Break-off Tool, slide the thumb piece distally.

5. The Reduction Screw Cap can be used on multiple screws as an alternative to the Counter-torque to restrict tulip splay during reduction (Fig. 3). After fully reducing the rod, remove the caps and use the Reduction Screw Counter-torque to secure the tulip while breaking off the extended tulip.

Tip: It is recommended to final tighten the lock screws prior to breaking off the Reduction Extensions to ensure the lock screw is seated below the extended tulip.

CAUTION

The Silencer and Gator Reducers are not compatible with polyaxial reduction screws or uniplanar reduction screws and may damage the implant if used. Only the Matador Reducer and Rocker may be used.

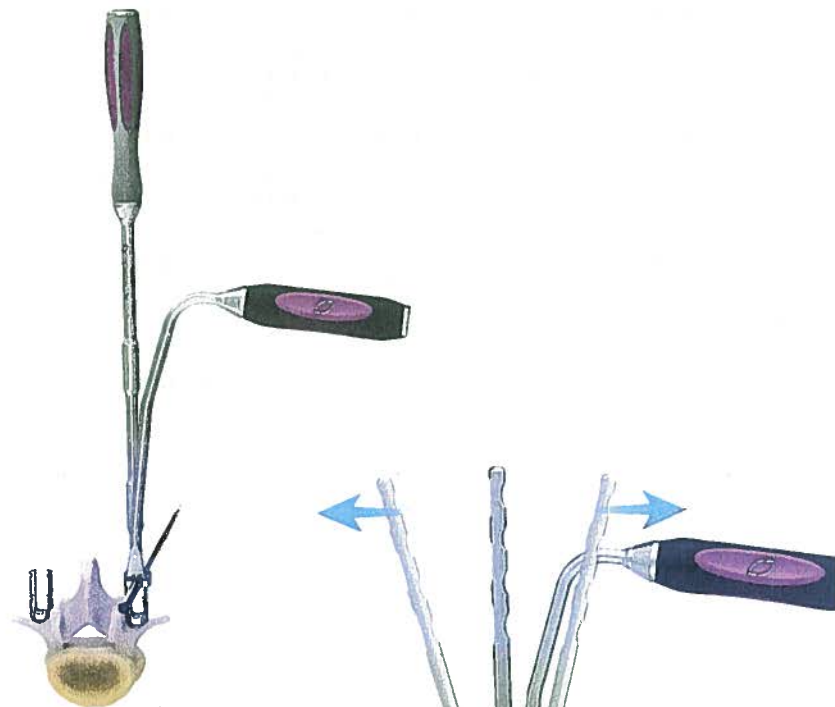

(Fig. 1)

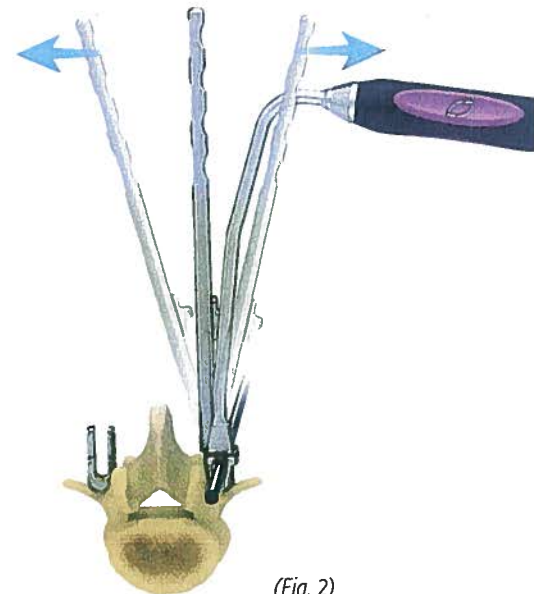

(Fig. 2)

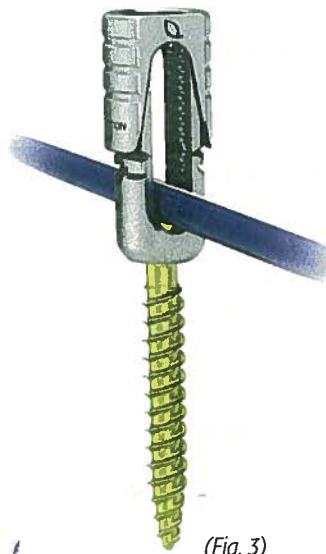

(Fig. 3)

RELINE™ – OPEN ADVANCED APPLICATIONS

OPEN TECHNIQUE GUIDE | OPEN ADVANCED APPLICATIONS | REDUCTION SCREWS | HOOKS | ILIAC SCREWS | ADJACENT SEGMENT FIXATION | VERTEBRAL BODY DEROTATION | OSTEOTOMIES

HOOKS

The Reline system offers a variety of hooks with anatomically contoured blades in a range of sizes.

1. The following instruments may be used to release the ligamentous attachment prior to hook insertion:

- Pedicle Elevator (Fig. 4)
- Lamina Elevator (Fig. 5)
- Transverse Process (TP) Elevator (Fig. 6)

2. Once the hook site has been properly prepared, choose the preferred inserter to securely engage the hook for placement.

- Threaded Hook Inserter (Fig. 7)
- Bilateral Hook Inserter (Fig. 8)
- Unilateral Hook Inserter (Fig. 9)

3. If impaction is desired, partially thread the Threaded Hook Inserter into the hook. Insert the Hook Pusher into the rod slot under the Threaded Hook Inserter (Fig. 7) and tighten the Threaded Hook Inserter onto the Hook Pusher until the instruments are secure.



(Fig. 4)



(Fig. 5)



(Fig. 6)

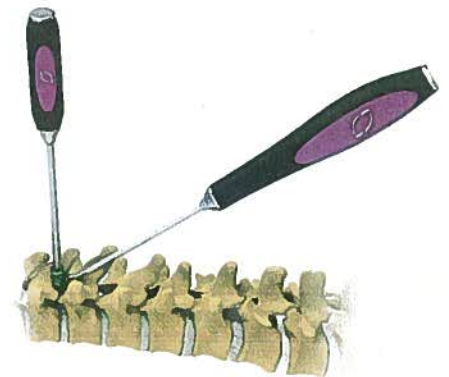

(Fig. 7)



(Fig. 8)



(Fig. 9)

RELINE™ – OPEN ADVANCED APPLICATIONS

OPEN TECHNIQUE GUIDE | OPEN ADVANCED APPLICATIONS | REDUCTION SCREWS | HOOKS | ILIAC SCREWS | ADJACENT SEGMENT FIXATION | VERTEBRAL BODY DEROTATION | OSTEOTOMIES

ILIAC SCREWS

Iliac fixation provides additional stability in long construct spinal fusions.

1. If iliac screw fixation is desired, expose the posterior superior iliac spine and decorticate the entry point using a burr or rongeur.
2. Use the Iliac Gearshift Probe to create a pilot hole, aiming for the thick bone just above the greater sciatic notch (*Fig. 10*). Inspect the pilot hole for cortical wall violations using the Dual-ended Ball Tip Pedicle Probe.
3. Tap the pilot hole using the markings on the shaft and fluoroscopy to monitor depth. Re-inspect the pilot hole for perforations.
4. With the ilium prepared, select the preferred type of iliac screw in the appropriate size.
 - If using an open tulip iliac screw, use the standard Polyaxial Screwdriver.
 - If using a closed iliac screw, use the Closed Iliac Screwdriver.
5. Insert the iliac screw into the pilot hole and advance until the desired depth is reached. If screw adjustment is needed, use the Screw Adjuster to adjust screw depth.

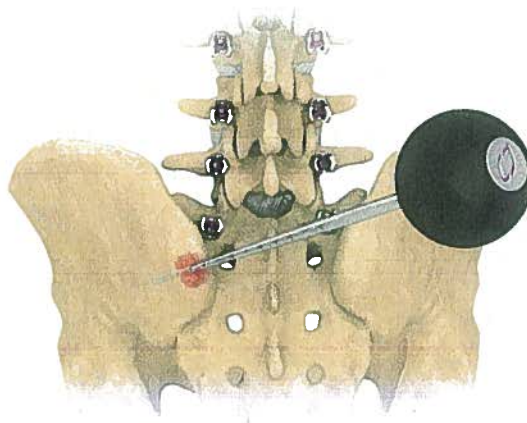

(Fig. 10)

Offset Iliac Connectors

An offset connector may be used to connect the iliac screw to the rod.

1. Determine the offset length required and use the Rod Holder to insert the shaft of the preferred connector into the rod slot of the iliac screw.
 - The Unilateral Inserter can be used to place open offset iliac connectors (*Figs. 11, 12*).
2. To hold the offset connector in position, insert the appropriate lock screw into the tulip of the iliac screw, using the Lock Screw Starter, and provisionally tighten the lock screw. Use the Open Offset Connector Counter-torque to final tighten the lock screw.

Note: Open iliac screws and open offset connectors accept the 5.5mm or 6.0mm cannulated lock screws.

Closed tulip lock screws must be used with closed iliac screws and closed offset connectors.

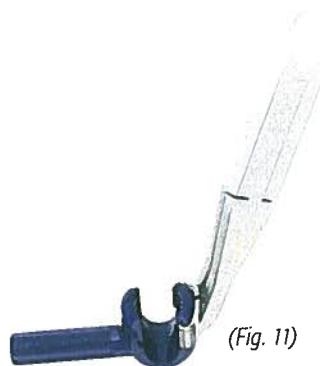

(Fig. 11)

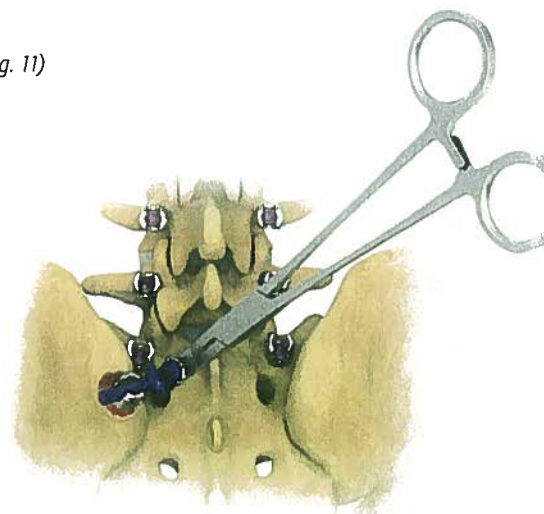

(Fig. 12)

RELINE™ — OPEN ADVANCED APPLICATIONS

OPEN TECHNIQUE GUIDE | OPEN ADVANCED APPLICATIONS | REDUCTION SCREWS | HOOKS | ILIAC SCREWS | ADJACENT SEGMENT FIXATION | VERTEBRAL BODY DEROTATION | OSTEOTOMIES

ADJACENT SEGMENT FIXATION

The Adjacent Segment Fixation (ASF) system provides instruments and implants designed to simplify revision surgery.

1. Determine the desired location for the rod-rod connector, and remove the fusion mass at that site with the 5.5mm or 6.35mm Bone Chisel. Once the rod is exposed, seat the chisel on the rod and rock it back-and-forth to remove all fusion mass necessary for placement of the rod-rod connector (Fig. 13).
2. If additional bone removal is required, utilize the Slotted Rongeur (Fig. 14).
3. Use the Unilateral Inserter to place an open offset rod connector onto the rod from a medial or lateral approach. Insert a lock screw with the Lock Screw Starter to provisionally secure the connector to the rod (Fig. 15).
4. Use an ASF Rod Template to estimate rod length. Contour and cut the offset rod to size.
5. Place the rod into the construct with the Rod Holder, and insert lock screws with the Lock Screw Starter to provisionally tighten.
6. Place the Rod-Rod Connector Counter-torque over the open tulip end of the connector. With the Torque T-handle (90 in-lbs) attached to the Final Lock Screw Driver, tighten the lock screw until the breakaway torque is reached (Fig. 16). Repeat on all appropriate levels.

Note: The Rod-Rod Connector Counter-torque only fits over open tulip connectors. For all other connectors, use the Open Screw Counter-torque on an adjacent screw during final tightening.

OPTIONAL

Utilize NuvaMap™ O.R. to assess the lumbar lordosis (LL) achieved and its effect on sagittal alignment (Pl-LL) in real-time after final rod placement and prior to closing (Fig. 17).

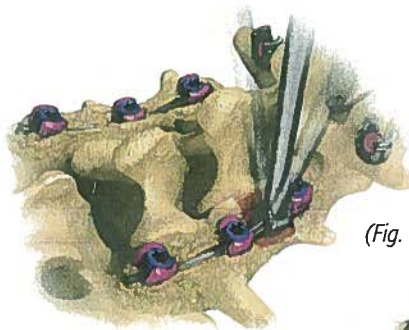

(Fig. 13)

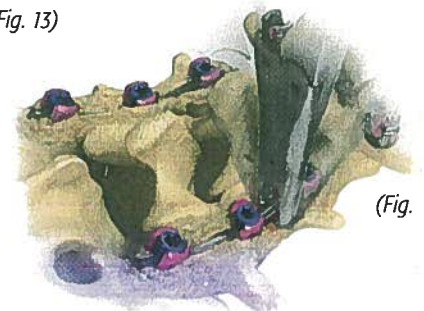

(Fig. 14)

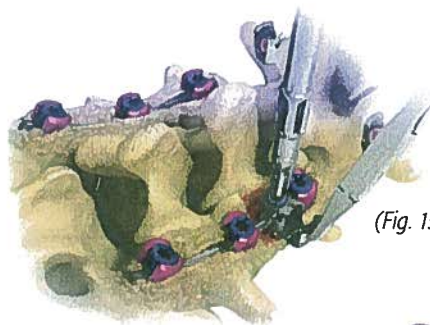

(Fig. 15)

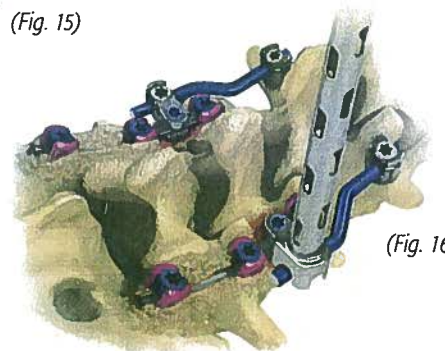

(Fig. 16)

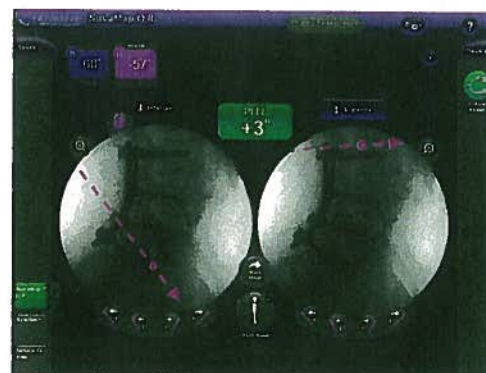

(Fig. 17)

RELINE™ – OPEN ADVANCED APPLICATIONS

OPEN TECHNIQUE GUIDE | OPEN ADVANCED APPLICATIONS | REDUCTION SCREWS | HOOKS | ILIAC SCREWS | ADJACENT SEGMENT FIXATION | VERTEBRAL BODY DEROTATION | OSTEOTOMY

VERTEBRAL BODY DEROTATION

Vertebral body derotation is performed by linking multiple screws together with instrumentation to drive axial correction of the spine. Derotation can be performed on a single vertebral body (segmental) or over multiple vertebrae (en bloc). Derotation Towers are the recommended instruments for derotation; however, Silencers, Gators, or MAS® Guides may also be linked together.

Segmental Derotation

Use preoperative radiographs to select the most caudal-neutral vertebral body as the starting point for segmental derotation.

1. On both the neutral vertebral body and the first superior rotated vertebral body, align the Derotation Towers with the tulips and apply downward pressure to engage the screws.
2. Connect the Coupled Segmental Derotation Link (Fig. 18) to the derotation towers across each vertebral body, and lock the set screws (Fig. 19).
3. Provisionally tighten the lock screws on the neutral vertebral body, leaving the lock screws loose on the rotated superior vertebral bodies (Fig. 20).
4. Using the neutral vertebral body as a reference, derotate the rotated vertebral body into a neutral position (Fig. 21). Provisionally tighten the lock screws with the Long Lock Screw Driver to hold correction (Fig. 22).
5. The derotated vertebral body is now used as the neutral segment for the next rotated level. This process is repeated until all vertebral bodies have been derotated into neutral positions.

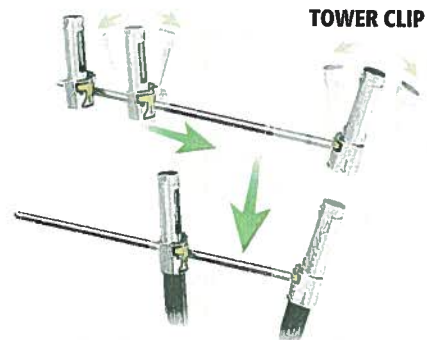

(Fig. 18)

SET SCREW

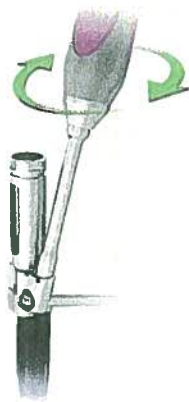

(Fig. 19)

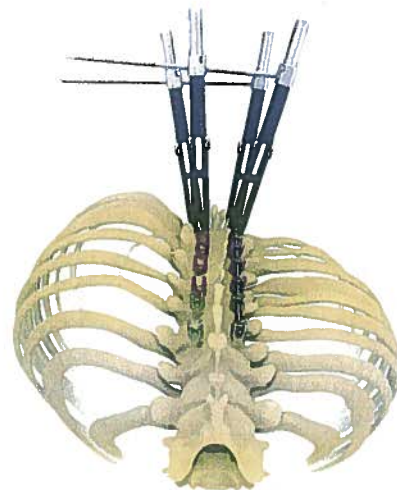

(Fig. 20)

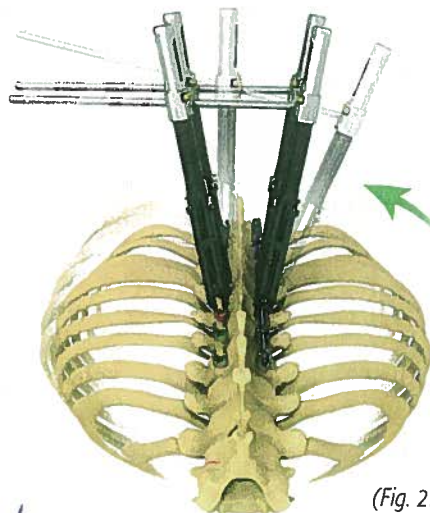

(Fig. 21)



(Fig. 22)

RELINE™ – OPEN ADVANCED APPLICATIONS

OPEN TECHNIQUE GUIDE | OPEN ADVANCED APPLICATIONS | REDUCTION SCREWS | HOOKS | ILIAC SCREWS | ADJACENT SEGMENT FIXATION | VERTEBRAL BODY DEROTATION | OSTEOTOMIES

**VERTEBRAL BODY DEROTATION
(CONT.)**

En Bloc Derotation

Use preoperative radiographs to identify the apex of the rotational deformity for the assembly of the en bloc construct.

1. On the selected vertebral bodies, align the Derotation Towers with the tulips and apply downward pressure to engage the screws.
2. Connect the Coupled Segmental Derotation Link (Fig. 18) to the derotation towers across each vertebral body, and lock the set screws.
3. Connect all the Coupled Segmental Derotation Links together with the Derotation Clamp and squeeze together to engage adjacent towers. Rotate the black locking lever into the locked position for a secure connection (Fig. 23).

Note: If bilateral clamping isn't achievable, unilateral clamping may provide adequate rigidity.

4. Construct a segmental frame that is inferior or superior to the en bloc frame as a reference during the derotation (Fig. 24).

Tip: Provisionally lock at least one lock screw at a neutral segment above and below the Derotation Towers to hold the rod in a fixed position.

5. Rotate the en bloc construct around the rod until the rotated vertebral bodies are in a neutral position (Fig. 25). Lock the correction by provisionally tightening the lock screws with a Ratcheting Handle attached to the Long Lock Screw Driver (Fig. 26).

Tip: Having an assistant push on the rib hump during derotation can aid in the correction maneuver.

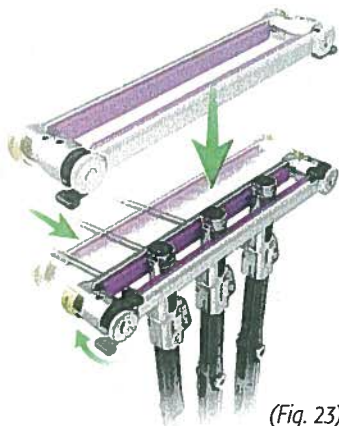

(Fig. 23)

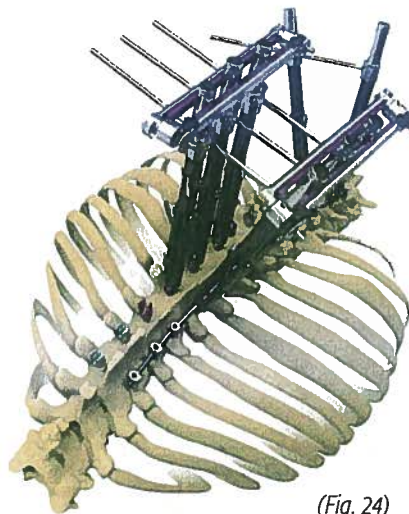

(Fig. 24)

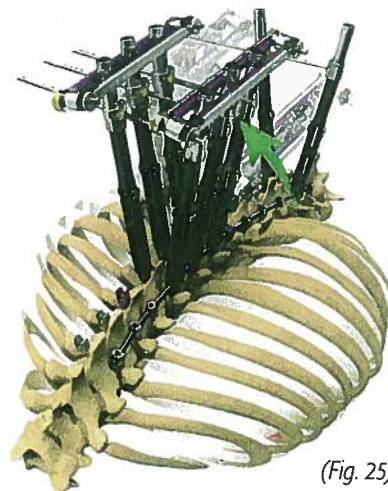

(Fig. 25)

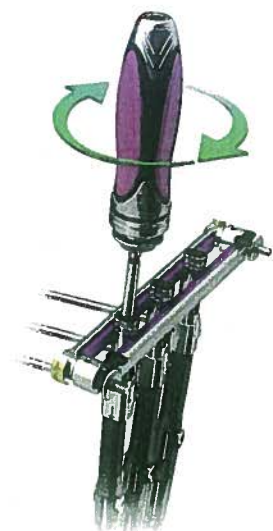

(Fig. 26)

RELINE™ – OPEN ADVANCED APPLICATIONS

OPEN TECHNIQUE GUIDE | OPEN ADVANCED APPLICATIONS | REDUCTION SCREWS | HOOKS | ILIAC SCREWS | ADJACENT SEGMENT FIXATION | VERTEBRAL BODY DEROTATION | OSTEOTOMIES

OSTEOTOMIES

The NuVasive® 3-Column Osteotomy (3CO) system provides specially designed instruments to simplify osteotomy techniques.

Pedicle Subtraction Osteotomy (PSO)

STEP 1:

POSTERIOR ELEMENTS RESECTION

Prior to beginning the PSO, the posterior elements must be fully exposed out to the medial side of the transverse process, and the posterior fixation hardware must be in place.

1. Use rongeurs, osteotomes and/or curettes to resect the posterior elements, leaving the pedicles intact. It is also recommended to remove a portion of the facets from the inferior and superior vertebral bodies (Fig. 27).

Tip: The transverse process can also be removed or disconnected from the pedicle to gain access to the lateral wall of the vertebral body for future steps.

STEP 2:

PEDICLE RESECTION

1. Use the Box Osteotomes to resect the pedicle by making two simultaneous cuts around the pedicle. One cut will be on the caudal side of the pedicle and another on the medial edge next to the dura (Fig. 28).

Tip: Nerve Root Retractors could be used to protect the dura and exiting nerve root.

2. Replicate the cut on the cephalad and medial side of the pedicle with the Box Osteotome.
3. Use either a Straight or Box Osteotome to finish the pedicle resection on the lateral side of the pedicle.
4. Another option for pedicle resection is the use of the Conical Shavers. The conical shavers can be used by spinning the shaver down the pedicle to decancellate, and then use a Kerrison to remove the cortical ring of the pedicle (Fig. 29).



(Fig. 27)



(Fig. 28)

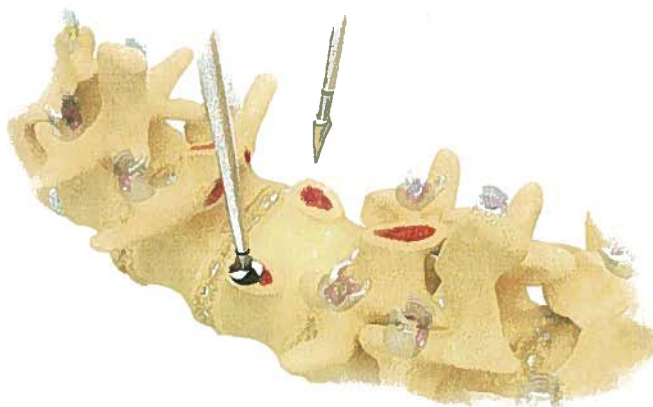

(Fig. 29)

RELINE™ – OPEN ADVANCED APPLICATIONS

OPEN TECHNIQUE GUIDE | OPEN ADVANCED APPLICATIONS | REDUCTION SCREWS | HOOKS | ILIAC SCREWS | ADJACENT SEGMENT FIXATION | VERTEBRAL BODY DEROTATION | OSTEOTOMIES

OSTEOTOMIES (CONT.)

Pedicle Subtraction Osteotomy (Cont.)

STEP 3:

VERTEBRAL BODY RESECTION

1. Place the Lateral Wall Retractors unilaterally or bilaterally around the vertebral body by using the distal tip to dissect soft tissue off the lateral wall of the vertebral body until the retractors are seated on the anterior portion of the vertebral body (Fig. 30).

Tip: The 3CO Cobb elevator can be utilized to help dissect the soft tissue off the vertebral body prior to the insertion of the Lateral Wall Retractors.

2. Press the hinge on the Lateral Wall Retractor and pivot the handle out of the surgical site.

Note: At this step, it is recommended to use either a temporary rod or the Reline 3CO Rack to stabilize the spine prior to continuing the vertebral body resection.

3. Decancellate the vertebral body with the use of either rongeurs, osteotomes, and/or curettes.

Tip: Be sure to leave the posterior wall of the vertebral body under the dura intact until the last step to support the vertebral body during final wedge cut of the vertebral body.

4. The final wedge cut of the lateral wall then can be achieved with either a straight osteotome or Kerrison to the desired angle (Fig. 31).

STEP 4:

WEDGE VERIFICATION

1. Place the Wedge Caliper into the decancellated vertebral body, resting the distal tip on the anterior cortex. Squeeze the caliper until there is a slight resistance against the vertebral body (Fig. 32).

2. The measurement reading at the top of the caliper will correlate with the wedge angle of the osteotomy (Fig. 32a).

Note: If a greater angle is needed, use either osteotomes or Kerrisons to remove additional bone until the desired angle is achieved.

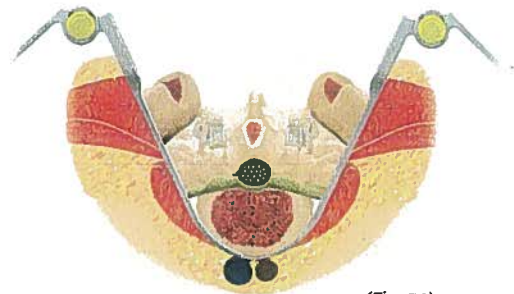

(Fig. 30)

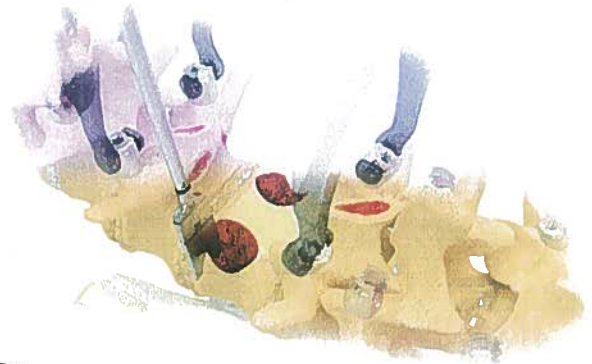

(Fig. 31)

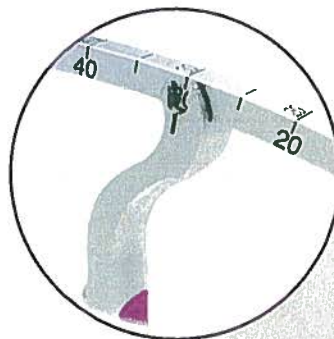

(Fig. 32a)



(Fig. 32)

RELINE™ – OPEN ADVANCED APPLICATIONS

OPEN TECHNIQUE GUIDE | OPEN ADVANCED APPLICATIONS | REDUCTION SCREWS | HOOKS | ILIAC SCREWS | ADJACENT SEGMENT FIXATION | VERTEBRAL BODY DEROTATION | OSTEOTOMIES

OSTEOTOMIES (CONT.)

Pedicle Subtraction Osteotomy (Cont.)

STEP 5:

POSTERIOR WALL RESECTION

1. Carefully place the Posterior Wall Impactor between the dura and the posterior wall with the heel resting against the posterior wall of the vertebral body (Fig. 33).
2. Use a mallet to strike the Posterior Wall Impactor and break the posterior wall of the vertebral body.

Tip: It is recommended to make two separate cuts, one at the cephalad edge of the wedge and one at the caudal end for complete resection of the posterior wall.

3. Remove the posterior wall from the osteotomy with a pituitary.

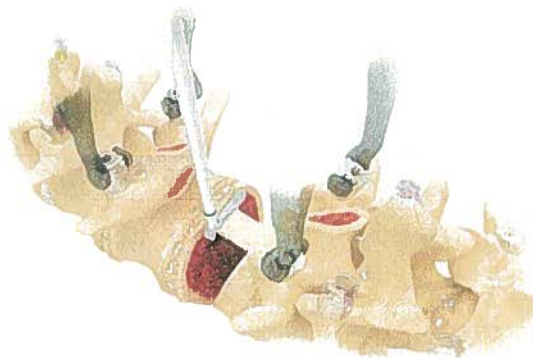

(Fig. 33)

STEP 6:

OSTEOTOMY CLOSURE

Using the 3CO Rack will provide the ability to close the osteotomy in a controlled manner, allowing the osteotomy to naturally close, based on the desired wedge cut.

1. Securely hold both 3CO Racks, switch each rack's lever into the C (Compression) position, and loosen the lock screws holding the rack to the screws.

Note: Do not remove the lock screws.

2. Bilaterally close both racks in a controlled manner by turning the black thumb piece clockwise until the osteotomy is fully closed (Fig. 34).

Tip: If additional bone removal is required at any point during the closure, switch the 3CO Racks into the D (Distraction) position, tighten the lock screws and remove the additional bone with the preferred method of bone removal.

3. Tighten the lock screws to hold the osteotomy closed and prepare the final rods for insertion.

4. Once the final rods are ready to be inserted, remove one rack, place the first final rod into place, and secure it with lock screws (Fig. 35). Repeat this step on the other side with the second final rod.

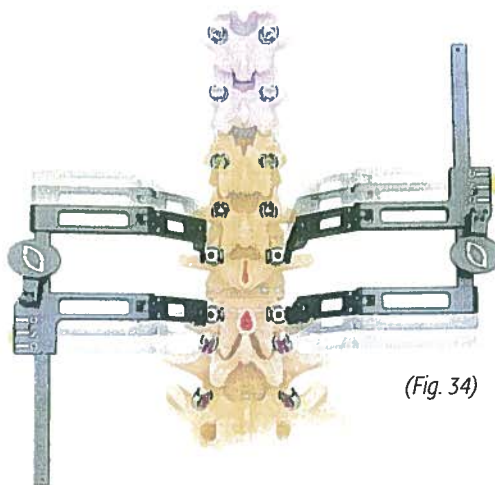

(Fig. 34)

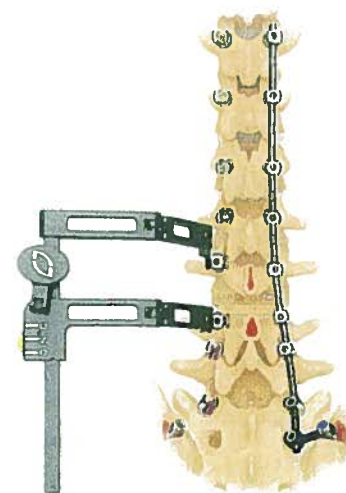

(Fig. 35)

RELINE™ —
MAS® CORE
TECHNIQUE GUIDE

RELINE™ – MAS® CORE TECHNIQUE GUIDE

CORE TECHNIQUE GUIDE | SHORT CONSTRUCT | REDUCTION SCREWS

RELINE MAS® EQUIPMENT REQUIREMENTS

- Reline MAS CORE Instrument Tray 1
- Reline MAS CORE Instrument Tray 2
- Reline MAS CORE Implant Tray
- C-arm Fluoroscope
- Radiolucent Surgical Table
- NVM5® System

OPTIONAL:

- Reline MAS 5.5mm Long Construct Tray
- Reline Reduction MAS Tray
- Reline Extra Guide/Reducer Tray
- NuvaMap™
- Bendini® Spinal Rod Bending System
- MAS Graft Delivery System

For a complete list of intended uses, indications, device description, contraindications, warnings, and precautions, please refer to the Instructions for Use (IFU) in the back of this technique guide.

RELINE™ – MAS® CORE TECHNIQUE GUIDE

CORE TECHNIQUE GUIDE | SHORT CONSTRUCT | REDUCTION SCREWS

PATIENT POSITIONING AND O.R. SETUP

Place the patient on the operating table in a prone position (Fig. 1). Prepare and drape in a conventional manner. The fluoroscope should have easy access to the surgical field for both A/P and lateral views. Uniplanar or biplanar fluoroscopy may be used. Fluoroscopic monitors and the NVM5® unit should be placed in clear view (Fig. 1). It is preferable to place the NVM5 unit at the foot of the bed.

Place the EMG/MEP neuromonitoring electrodes on the patient. If SSEP monitoring is planned for the surgery, place these electrodes as well.

Once electrodes are properly placed, execute a Twitch Test to determine if neuromuscular blockades are out of the patient's system and if effective neuromonitoring can be accomplished.

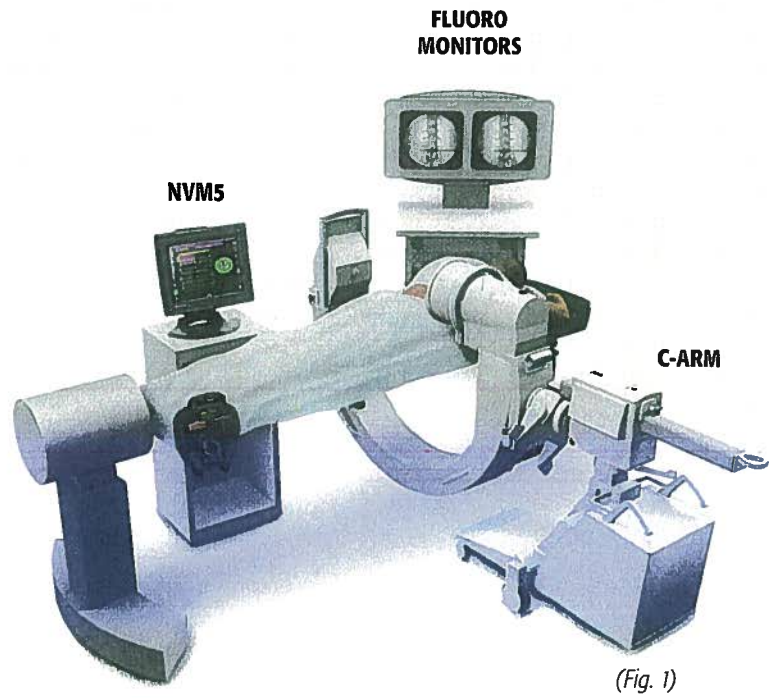

(Fig. 1)

NVM5 INTRAOPERATIVE MONITORING



Free Run EMG



Dynamic EMG

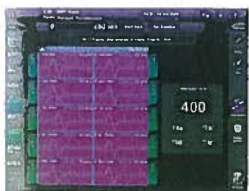

MEP



SSEP

RELINE™ – MAS® CORE TECHNIQUE GUIDE

CORE TECHNIQUE GUIDE | SHORT CONSTRUCT | REDUCTION SCREWS

STEP 1: TARGETING AND ACCESSING PEDICLES

1. Using A/P fluoroscopy, place a K-wire longitudinally along the lateral margins of the targeted pedicles (*Figs. 2, 4*).
2. Move the K-wire laterally 1-3cm, depending on the size of the patient, and mark the skin along the K-wire.
3. Place the K-wire perpendicular to the longitudinal line over the center of the pedicle (*Figs. 3, 5*) and mark the skin. The intersection of the two lines represents the skin incision location and entry point for the I-PAS™ III needle.

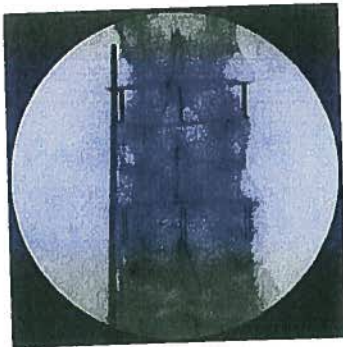

(Fig. 4)

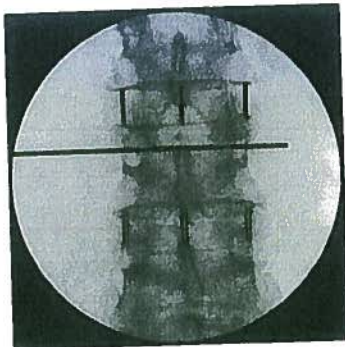

(Fig. 5)

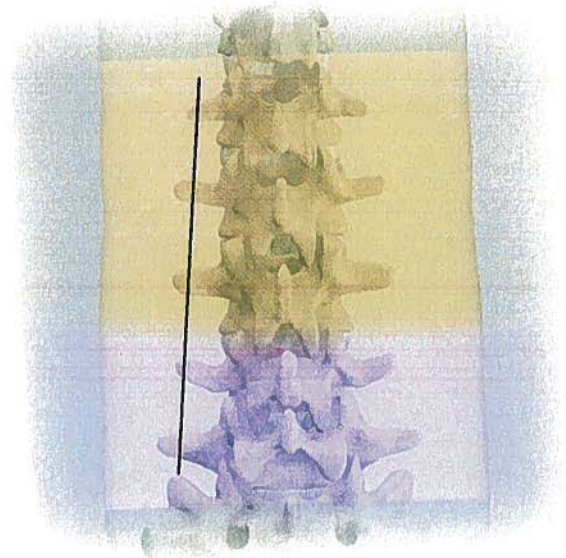

(Fig. 2)

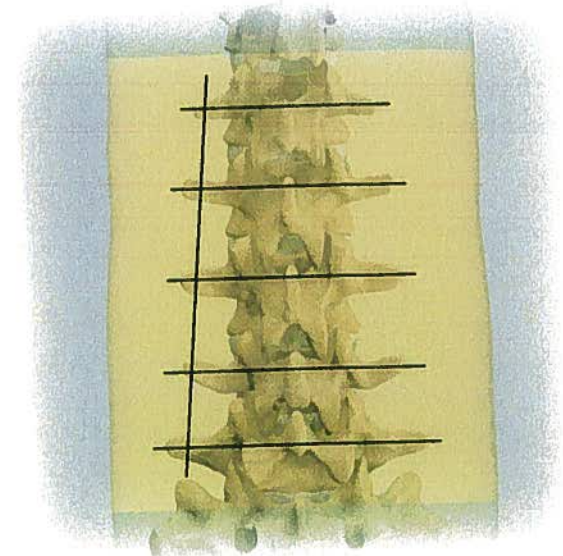

(Fig. 3)

RELINE™ – MAS™ CORE TECHNIQUE GUIDE

CORE TECHNIQUE GUIDE | SHORT CONSTRUCT | REDUCTION SCREWS

**STEP 1:
TARGETING AND ACCESSING PEDICLES (CONT.)**

1. Make a 2cm skin incision at the intersection of the two previously drawn lines.
2. With the NVM5® Dynamic Stimulation Clip attached, initiate NVM5 Dynamic Stimulation mode and insert the I-PAS™ III needle through the incision.
3. Advance the tip down to the transition of the transverse process and facet joint (Fig. 6).
4. Using A/P fluoroscopy, verify the needle is positioned slightly superior and lateral to the center of the pedicle (Fig. 7).
5. Insert the tip of the I-PAS III needle a few millimeters into the bone to secure its position. Prior to advancing into the pedicle, use lateral fluoroscopy to verify that the trajectory follows a line through the pedicle (Fig. 8).
6. With an oblique trajectory, advance the I-PAS III needle into the pedicle. Continue to pass the needle, using a combination of fluoroscopy and NVM5 for guidance (Fig. 9). Milliamp (mA) values get progressively lower as I-PAS III approaches the cortical wall, providing an opportunity to redirect prior to a breach (Fig. 10).

Tip: To potentially save time and reduce the number of lateral fluoroscopy shots, use the integrated depth gauge on the I-PAS III needle to determine how far into the pedicle you have cannulated.

7. Remove the I-PAS III stylet and introduce a K-wire through the cannulation, leaving approximately 1cm of the K-wire extending into the vertebral body (Fig. 9).
8. Remove the I-PAS III needle, leaving the K-wire in position.
9. For better K-wire management, use the K-wire Holder by attaching the clip to the table drape (Fig. 11) and place K-wires through the K-wire Holder.



(Fig. 6)

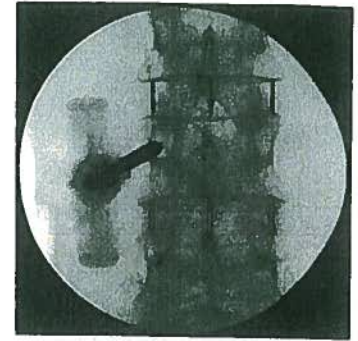

(Fig. 7)

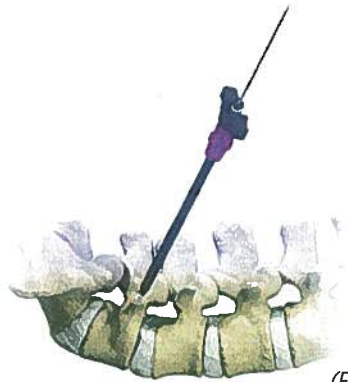

(Fig. 9)

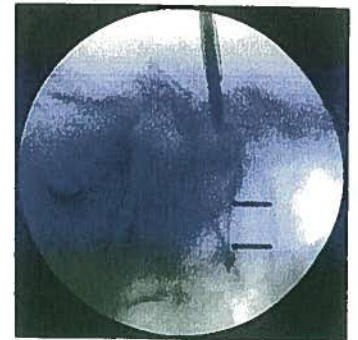

(Fig. 8)



(Fig. 10)

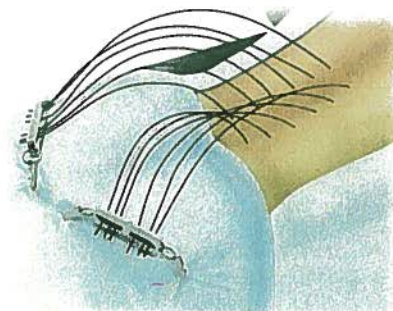

(Fig. 11)

RELINE™ – MAS® CORE TECHNIQUE GUIDE

CORE TECHNIQUE GUIDE | SHORT CONSTRUCT | REDUCTION SCREWS

K-wire Advancement/Removal (Optional)

1. Begin by opening the inner cannulation of the K-wire Driver by depressing the lever on the body of the driver and introducing the driver over the K-wire (Fig. 12).
2. Once the desired position on the K-wire is reached, release the lever to secure the driver in position (Fig. 12a).
3. Use the integrated slap hammer to either advance (A) or remove (B) the K-wire, using lateral fluoroscopy to monitor depth.

CAUTION
K-wire should be removed when screw has reached the posterior wall of the pedicle to avoid a kink in the tip.



RELINE™ – MAS® CORE TECHNIQUE GUIDE

CORE TECHNIQUE GUIDE | SHORT CONSTRUCT | REDUCTION SCREWS

**STEP 2:
INSERT FASCIAL SPLITTER (OPTIONAL)**

Using a scalpel, ensure the skin incision has been optimized to the blade dimensions of the Fascial Splitter Handle (Fig. 13).

Note: The Fascial Splitter Blade is 18.9mm wide and is not used to cut skin – only to clear a path through the fascia.

Loading:

1. Open the disposable Fascial Splitter Blade and have the scrub tech hold the plastic tip and thread the Fascial Splitter Handle by rotating the proximal gold knob clockwise (keeping a slight axial downward force) until the blade is fully secured, and the gold knob no longer rotates (Fig. 14).
2. Now remove the plastic protective tip, as the blade is ready for use.

To Use:

1. Slide the distal tip of the blade over the K-wire via the cannulation, and create a path through the fascia until the blade docks on the bone (Fig. 15).
2. Once an adequate path has been created, remove the blade from the surgical site. Repeat this step over the remaining K-wires/screw insertion sites.

Removal:

1. On the back table, remove the disposable Fascial Splitter Blade by turning the proximal gold knob counterclockwise so it is no longer secured to the handle.
2. Dispose of the Fascial Splitter Blade according to proper sharps protocol.

CAUTION

Ensure the K-wire is not advancing as the path is created over the K-wire.

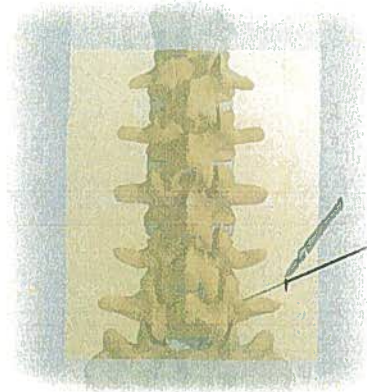

(Fig. 13)

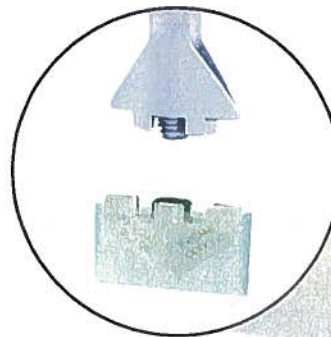

(Fig. 14)

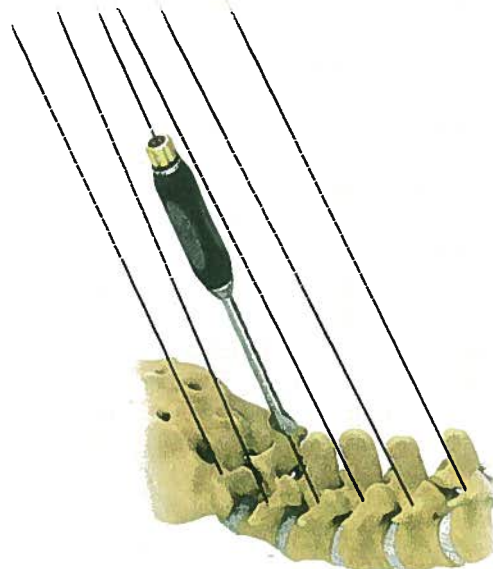

(Fig. 15)

RELINE™ – MAS® CORE TECHNIQUE GUIDE

CORE TECHNIQUE GUIDE | SHORT CONSTRUCT | REDUCTION SCREWS

STEP 3: FACET PREPARATION WITH THE FACET TUBE (OPTIONAL)

The Reline Facet Tube may be utilized if posterior facetectomies and minor osteotomies are required. Use of the sequential dilators (Primary Dilator, Tap Dilator) with Facet Tube Dilator will be required during this step.

1. Insert the Primary Dilator at the junction of the inferior and superior articular facets. The Reline Primary Dilator has a radiodense metal tip which may be used, with fluoroscopy, to target the facet(s) (Figs. 16, 16a).

Note:

- Additional skin incision may be required to advance the Facet Tube into the exposure. The diameter of the Facet Tube is 22mm.
- The K-wire channel may be used on the side of the Facet Tube to orient placement of the Facet Tube over the facet(s), once docked on bone, if a K-wire has been placed previously.
- The Facet Tube has a light source track, which will allow light source cables to be placed into the Facet Tube for better visualization (Fig. 18).

If additional rigidity is needed, the MaXcess® 4 Articulating Arm can be attached to the poker chip on the Facet Tube.

2. Once the facet(s) are properly targeted, insert the Tap Dilator over the top of the Primary Dilator (Fig. 17).
3. Insert the Facet Tube Dilator over the Tap Dilator until it docks on bone (Fig. 17).
4. Once proper placement is achieved, attach the Facet Tube Handle to the Facet Tube by engaging the poker chip features and turning clockwise. Then insert the Facet Tube over the top of the Facet Tube Dilator into the exposure, and remove the dilators (Fig. 18).

STEP 4: BIOLOGICS DELIVERY

Decorticate and/or complete bony removal through the Facet Tube. NuVasive® biologics – Osteocel® Pro, Osteocel Plus, or FormaGraft® – may be placed into the site manually or via the MAS® Graft Delivery system.

Refer to the MAS Graft Delivery system technique guide (9501278) for step-by-step instructions on use of the system.

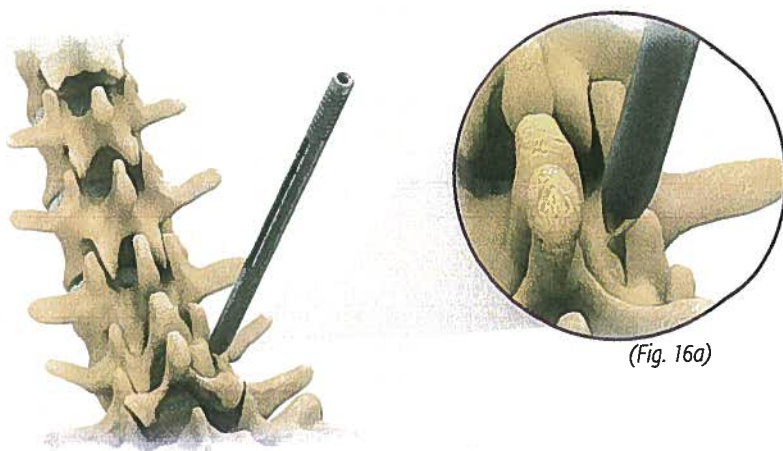

(Fig. 16)

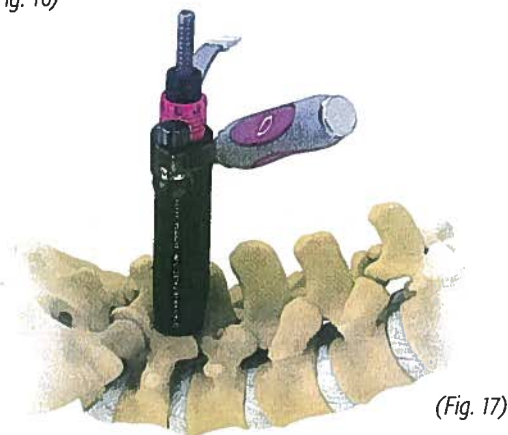

(Fig. 17)

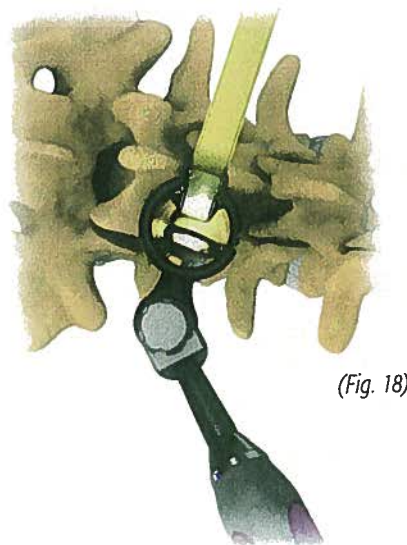

(Fig. 18)

RELINE™ – MAS™ CORE TECHNIQUE GUIDE

CORE TECHNIQUE GUIDE | SHORT CONSTRUCT | REDUCTION SCREWS

STEP 5:
INSERT DILATORS

Introduce the Primary Dilator over the K-wire and advance to the pedicle (Fig. 19).

- Reline dilators are radiodense, enabling their position to be verified fluoroscopically.
- Sequentially dilate with the Tap Dilator and Screw Dilator, ensuring all dilators are fully seated onto bone (Fig. 20).

Note: Prior to inserting the Primary Dilator, the Fascial Splitter may be used to optimize the skin incision. See Step 2 (Fig. 14) on page 45.

Screw Shank Measurement Technique (Optional)

Advance the K-wire to the desired screw shank depth. The appropriate screw shank length is estimated by the intersection of the most distal lasermark on the K-wire and the window of the dilator (Fig. 19a).

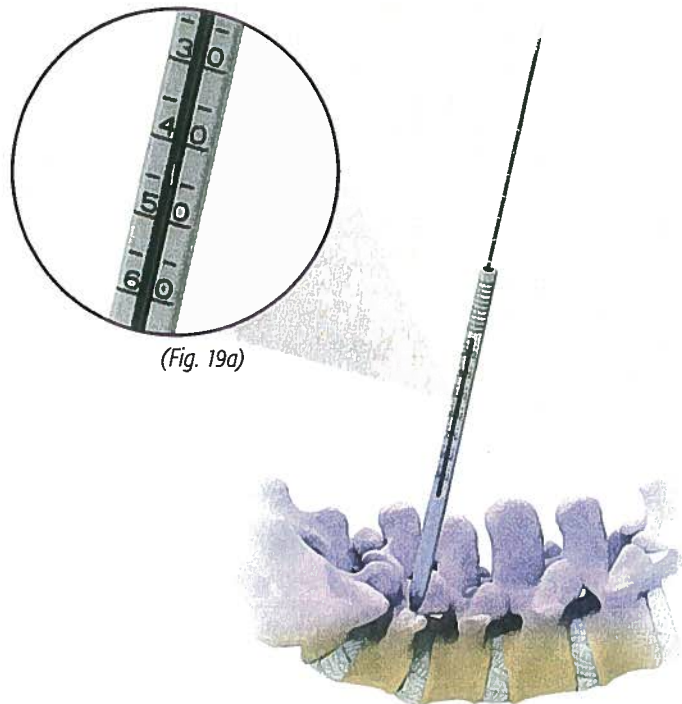

(Fig. 19)



(Fig. 20)

RELINE™ – MAS™ CORE TECHNIQUE GUIDE

CORE TECHNIQUE GUIDE | SHORT CONSTRUCT | REDUCTION SCREWS

STEP 6: PILOT HOLE PREPARATION

1. Remove the Primary Dilator, leaving the K-wire, Tap Dilator, and Screw Dilator in position.
2. Attach the NVM5® Dynamic Stimulation Clip to the Dynamic Stimulation Ring below the handle of the appropriate Tap (Fig. 21).
3. Initiate NVM5 Dynamic Stimulation mode and tap to the desired depth.

Tip: Watch lines on K-wire to help avoid K-wire advancement or pullout. Tap only slightly beyond the posterior wall and into the cancellous bone of the vertebral body to avoid K-wire advancement and kinking.

Note: The thread length is 40mm and can be used as a reference when determining screw length. In addition, the depth markings on the Tap, as measured from the top of the Tap Dilator, can also be used to estimate screw length.

CAUTION

Use lateral fluoroscopy to properly manage the K-wire during pedicle preparation to confirm proper placement and avoid anterior advancement of the K-wire.

NVM5



Use NVM5 to monitor nerve proximity and pedicle integrity during tapping. Stimulate in Dynamic Stimulation mode.



(Fig. 21)

RELINE™ – MAS® CORE TECHNIQUE GUIDE

CORE TECHNIQUE GUIDE | SHORT CONSTRUCT | REDUCTION SCREWS

STEP 7:
TAP/DILATOR COMBO (OPTIONAL)

1. Press the button on the Tap Dilator, and then pass the Tap through the dilator until it is securely retained (*Fig. 22*).
2. When the dilator is fully seated onto the bone, press the button on the Tap/Dilator Combo to release the Tap and tap to the desired depth.

Note: The depth markings on the Tap, as measured from the top of the Tap/Dilator Combo, can also be used to estimate screw length.

CAUTION

The Screw Dilator is not designed to sequentially dilate with the Tap/Dilator Combo.



(Fig. 22)

RELINE™ — MAS® CORE TECHNIQUE GUIDE

CORE TECHNIQUE GUIDE | SHORT CONSTRUCT | REDUCTION SCREWS

STEP 8: GUIDE ENGAGEMENT TO THE PEDICLE SCREW

1. Place the Guide Acorn Tool into the proximal end of the Guide.
2. Turn the Guide Acorn Tool counterclockwise until the silver castle nut is completely backed out.
3. With the screw in the caddy, align the tulip rod slot with the rod slot on the Guide, and then apply downward (axial) pressure until the Guide engages the screw (Fig. 23).
4. With the screw engaged, turn the Guide Acorn Tool clockwise until the silver castle nut sits flush with the proximal end of the Guide.

Note: Verify proper engagement of the Guide to the pedicle screw in two ways:

Ensure the silver castle nut sits flush within the proximal end of the Guide (Fig. 23a).

Ensure the two white lines on the distal end of the Guide are aligned prior to implanting the screw (Fig. 24).

If doing a 1- to 2-level construct with Open-Top Guides, please refer to the MAS® Short Construct portion (pages 73-78) of this technique guide for step-by-step instructions on proper loading of screws.

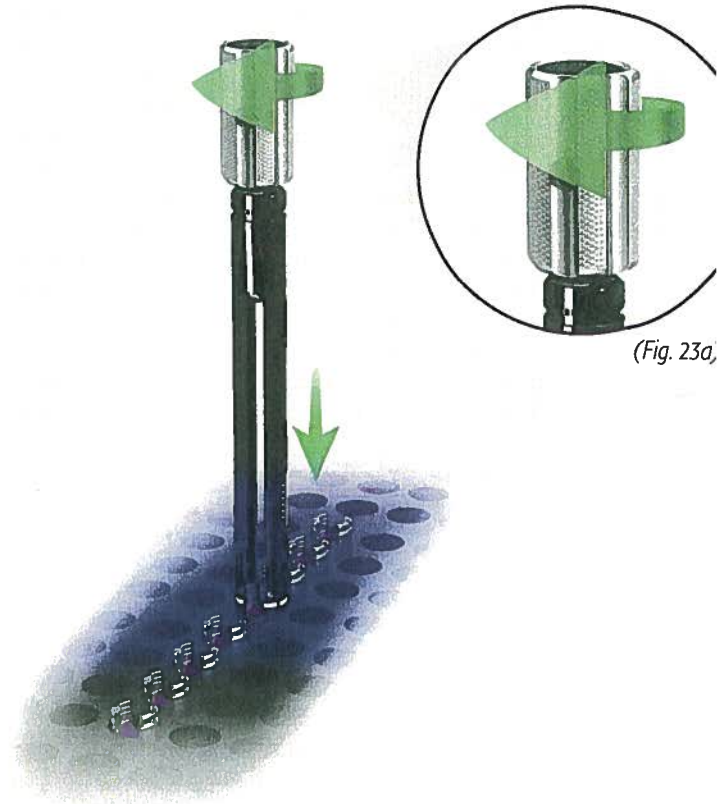

(Fig. 23)



(Fig. 24)

RELINE™ – MAS® CORE TECHNIQUE GUIDE

CORE TECHNIQUE GUIDE | SHORT CONSTRUCT | REDUCTION SCREWS

**STEP 9:
SCREW INSERTION**

1. Attach the Straight Short Ratcheting Handle to the Reline MAS® Screwdriver.
2. Insert the screwdriver through the Guide until the screwdriver tip engages in the screw shank.
3. Secure the screwdriver into position by turning the thumbwheel section clockwise to thread the screwdriver tip into the screw head.
4. Prior to screw insertion, confirm the screw shank and screwdriver are axially aligned.
5. Remove the Tap Dilator, leaving the K-wire and Screw Dilator in position.
6. Attach the NVM5® Dynamic Stimulation Clip, and then advance the screw over the K-wire into the pedicle.
7. Advance the screw until the tip reaches the posterior wall of the vertebral body.

Note: Ensure the pedicle screw is not driven down so far onto the bone that it prevents full polyaxial motion of the screw head as this will make rod insertion more difficult and can prevent the rod from normalizing properly in the tulip.

8. Remove the K-wire. Continue to advance the screw into the vertebral body until the screw is at the desired depth/position (Fig. 25).
9. Release the screwdriver from the screw head by turning the thumbwheel section counterclockwise.
10. Once the threads are fully disengaged from the screw head, remove the screwdriver from the Guide.
11. Remove the Screw Dilator and rotate the Guide in an orbital motion to ensure full polyaxial motion of the screw head is maintained.

Note: If fine adjustments are needed to the screw height, use of the Calculated Shank Adjuster should be utilized.



(Fig. 25)

NVM5



Use NVM5 to monitor nerve proximity and pedicle integrity during screw insertion. Stimulate in Dynamic Stimulation mode.

RELINE™ – MAS® CORE TECHNIQUE GUIDE

CORE TECHNIQUE GUIDE | SHORT CONSTRUCT | REDUCTION SCREWS

STEP 10: OPEN-TOP GUIDE ENGAGEMENT TO THE PEDICLE SCREW

Open-Top Guides are available to re-attach and positively engage the tulip. The Open-Top Guides can be used as a standard Guide for rod manipulation.

Steps for re-attachment

1. Insert the Reattachment Tool into the tulip. (Note: If the lock screw is in the tulip, a Final Driver can be used to engage the tulip.)
2. Slide the Open-Top Guide over the top of the Reattachment Tool (Fig. 26).
3. Align black lines on Guide and Reattachment Tool; then apply downward axial pressure until Guide positively engages the tulip.
4. Remove the Reattachment Tool.

Tip: The Standard Slip-on Guide or Open-Top Guide can also attach to the Reline MAS® reduction screws.



(Fig. 26)

NUVAMAP™ O.R.

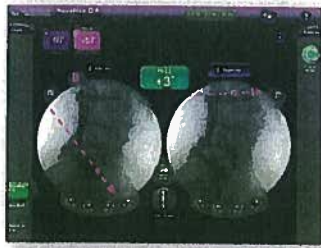

Manually input preoperative and planned pelvic parameter measurements into Nuvamap O.R. Measure L1 and S1 endplates on imported fluoro images to assess sagittal alignment relative to the PI-LL Alignment Indicator.

Optional: Utilize NVM5® Nuvamap O.R. software after screw placement to assess intraoperative lordosis.

RELINE™ – MAS™ CORE TECHNIQUE GUIDE

CORE TECHNIQUE GUIDE | SHORT CONSTRUCT | REDUCTION SCREWS

**STEP 11:
ROD MEASUREMENT**

Insert the arms of the Rod Measurement Tool into the proximal ends of the inferior and superior Guides, and advance the arms down into the screw heads (Fig. 27).

- Full seating of the Rod Measurement Tool is confirmed when the grooves at the top of the arms are positioned at the top of both Guides (Fig. 27a).
- It may be necessary to angle the Rod Measurement Tool cephalad and caudal to fully seat the distal end of the measurement tool into the screw heads.
- It is important to note the displayed measurement will indicate the distance between the screw shanks (Fig. 27b).
- The surgeon will add length, as necessary.

Note: It will be necessary for the surgeon to add length to the rod, depending upon patient anatomy and desired lordosis. As a general rule, add 15-20mm, depending on length of construct. If the measurement is in-between rod sizes, always round up to the next rod length. For long constructs, it may be necessary to add more length.

CAUTION

The **bulleted portion of the nose of the rod MUST extend fully outside of the most inferior tulip on the construct.** The lock screw **CANNOT** be locked down on this unusable portion of the rod. The same rule applies for the **faceted portion of the rod (where the Inserter locks down on the rod).** You **MUST** lock down on only usable portions of the rod with lock screws (Fig. 28).

Tip: Lay a Rod Template on the skin next to the Guides. Measure the distance between the most inferior/superior Guides and add 15-20mm to account for lordosis and bend of the rod.

Measure the rod with the Rod Measurement Tool and add 15-20mm. Attach the measured rod to a Rod Inserter. Take the Rod Inserter and lay it on the side of the patient's skin while aligning the inserter with the most superior guide so it is flush with the Guide entry point. Take a shot of fluoroscopy to help determine if the selected rod will be long enough for the construct.

Measure the rod with the Rod Measurement Tool and add 15-20mm. Take the selected rod and insert it into the rod slot at the tops of the Guides with the faceted portion of the superior end of the construct. This will help determine if the rod is long enough for the construct as long as the bulleted portion of the rod is fully exposed on the inferior end of the construct.

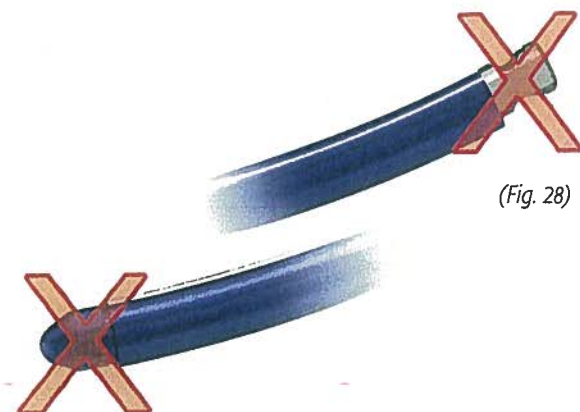
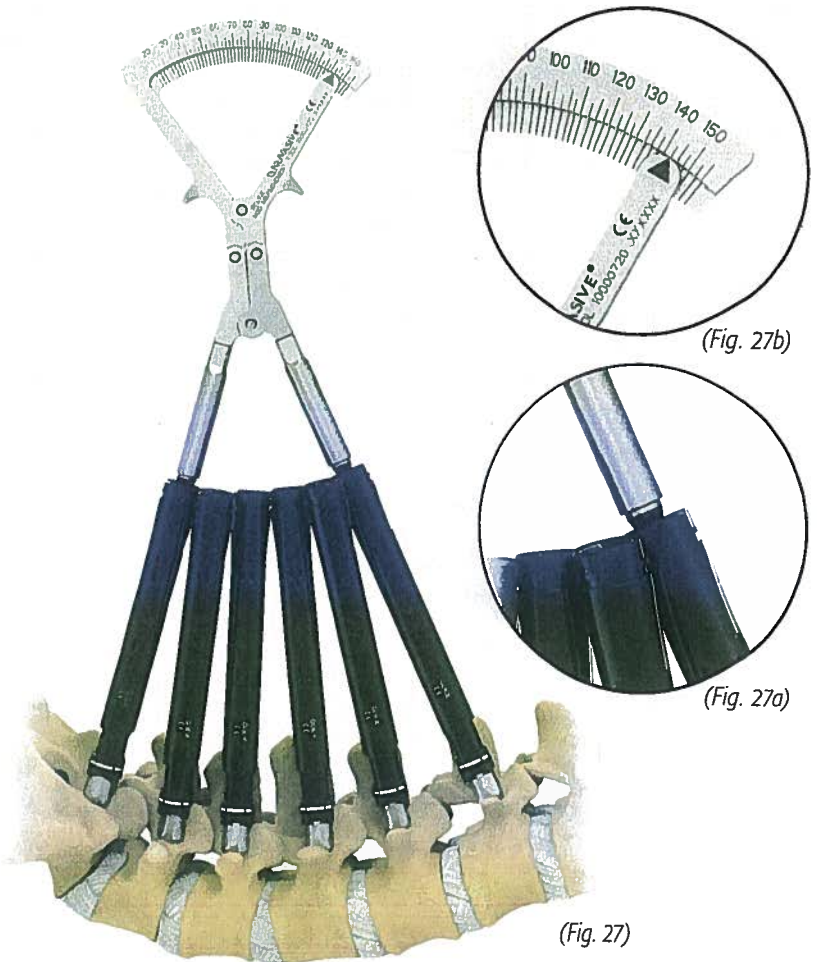

RELINE™ – MAS® CORE TECHNIQUE GUIDE

CORE TECHNIQUE GUIDE | SHORT CONSTRUCT | REDUCTION SCREWS

STEP 12: ROD MEASUREMENT/BENDING (OPTIONAL)

Bendini® Use

The Bendini spinal rod bending system expedites manual rod manipulation via computer-assisted bend instructions. This benefits both surgeons and patients with:

Decreased O.R. Time

Predictable, reproducible rod bending helps surgeons create rods, often requiring a single pass.¹

Restored Alignment

Surgeon-driven menus enable rapid intraoperative alignment assessment and rod customization. Coronal and sagittal design tools help guide surgeons to achieve alignment goals prior to exiting the O.R.

Minimized Screw Strain

Patient-specific rods are designed to minimize forces on the screw bone interface and minimize unnecessary preloading of the construct.²

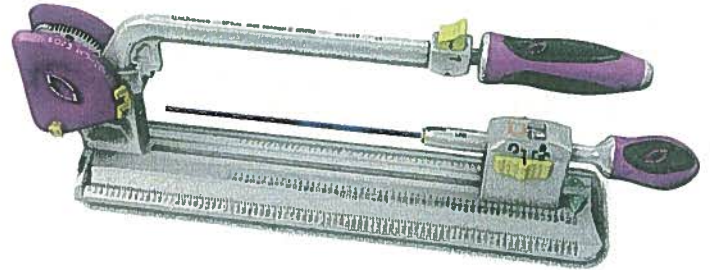

(Fig. 29)

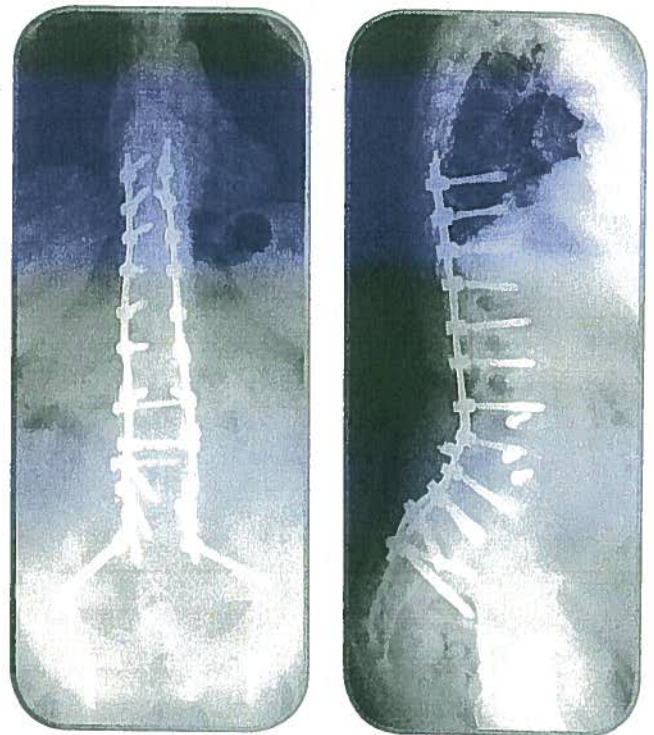

(Fig. 30)

SAGITTAL BENDING



CORONAL STRAIGHTENING



¹Wupperman RM, Isaacs RE, Taylor WR. The Bendini spinal rod bending system for long percutaneous pedicle screw constructs: cadaveric utility study and early clinical experience. Society of Lateral Access Surgery (SOLAS) 2013 Annual Meeting. San Diego, CA, USA.

²Tohmeh AG, Isaacs RE, Dooley ZA, et al. Long construct pedicle screw reduction and residual forces are decreased using a computer-assisted rod bending system. *J Spine Neurosurg* 2014;S2.

RELINE™ — MAS® CORE TECHNIQUE GUIDE

CORE TECHNIQUE GUIDE | SHORT CONSTRUCT | REDUCTION SCREWS

**STEP 13:
ROD INSERTION**

Prior to insertion, incise between the Guides. Align the rod slot of the Guides along the rod pathway by utilizing the Guide Head Adjuster. Provide a clear pathway between the Guides by inserting a scalpel.

Fixed Obtuse Rod Inserter

1. Place the faceted end of the rod into the distal tip of the Fixed Obtuse Rod Inserter (Fig. 31a).

Note: Reline rods can be inserted in both lordotic and kyphotic orientations; ensure the rod is engaged in the surgeon's desired orientation prior to locking the rod to the Rod Inserter.

2. Engage the Inserter Driver into the hexalobe on the proximal end of the inserter.
3. Turn the Inserter Driver clockwise to engage and lock the rod to the Fixed Obtuse Rod Inserter (Fig. 31).
4. To remove the rod, engage the Inserter Driver into the hexalobe on the proximal end of the inserter and turn counterclockwise.

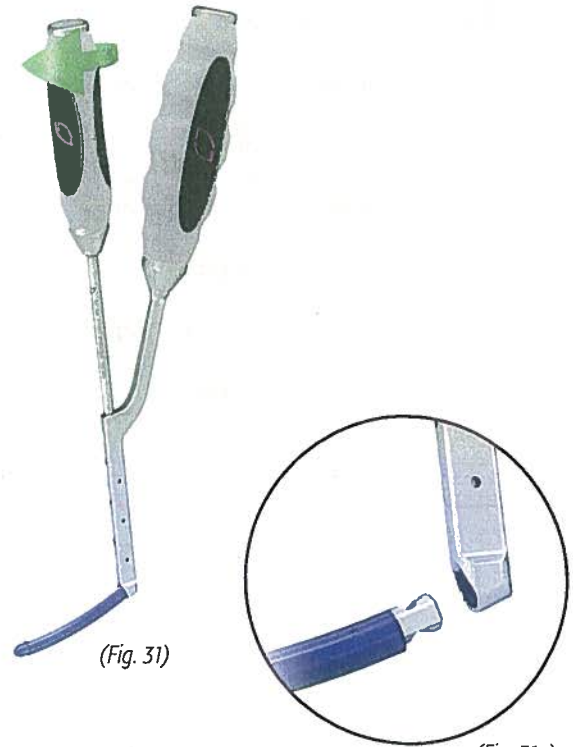

(Fig. 31)

(Fig. 31a)

Adjustable Rod Inserter

1. In the 90° position, turn the knurled knob counterclockwise on the proximal end of the Adjustable Rod Inserter.
2. Place the faceted end of the rod into the distal tip of the inserter.
3. Turn the knurled knob clockwise ("A") to lock the faceted end of the rod to the inserter. To adjust the angle of the rod, pull up (axially) ("B") on the knurled knob (Fig. 32).
4. To remove the rod, the Adjustable Rod Inserter must be in the 90° position. Turn the knurled knob counterclockwise to release.

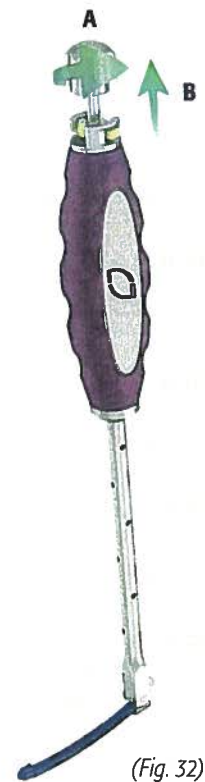

(Fig. 32)

Note: To remove the rod, the Adjustable Rod Inserter must be in the 90° position.

RELINE™ — MAS® CORE TECHNIQUE GUIDE

CORE TECHNIQUE GUIDE | SHORT CONSTRUCT | REDUCTION SCREWS

STEP 13: ROD INSERTION (CONT.)

Prior to rod insertion, it is important to align the Guides so that there is a smooth lordotic curvature between the tops of the Guides (Fig. 33).

- In addition, align the rod slot of the Guides along the rod pathway and connect the skin incisions. Insert the rod along the skin into the superior Guide with a trajectory toward the adjacent, inferior screw.

Tip: Use the Guide Head Adjuster to ensure the Guide does not rotate (i.e., the rod is not within the Guide window). The smooth side of the Dual-ended Rod Pusher can be used to verify the rod is through the Guide, as well as to indicate how much reduction may be needed. The Curved Tissue Dissector may also be used to help clear a pathway prior to rod insertion.

- This technique can be used with the Adjustable Rod Inserter (Fig. 32 on page 56), or Fixed Obtuse Rod Inserter (Fig. 31 on page 56).
- Advance the rod through the Guides while pushing the handle of the Rod Inserter toward the skin, as necessary, to fully insert the rod.
- It may be necessary to make fine adjustments to the angle and rotation of the Guides and Rod Inserter during rod passage to accommodate variances in medial/lateral screw alignment.
- This can be done with the Guide Head Adjuster.

STEP 14: LOCK SCREW INSERTION Expandable Lock Screw Starter

1. Ensure the gold knob is turned counterclockwise one full turn.
2. With the lock screw in the caddy, engage the Expandable Lock Screw Starter into the lock screw. Rotate the proximal gold knob clockwise to expand the hexalobe tip and retain the lock screw (Fig. 34).
3. Deliver the lock screws through the Guide until the 0mm marking on the shaft of the Expandable Lock Screw Starter is recessed below the proximal end of the Guide.
4. To release the lock screw, turn the gold knob counterclockwise and remove the Expandable Lock Screw Starter from the lock screw by pulling up (axially).

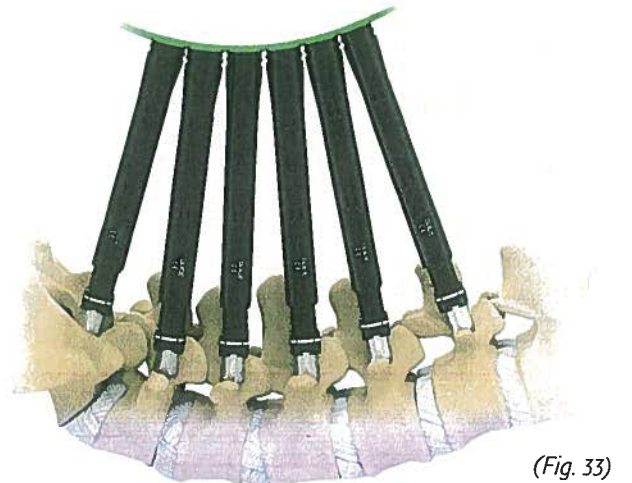

(Fig. 33)

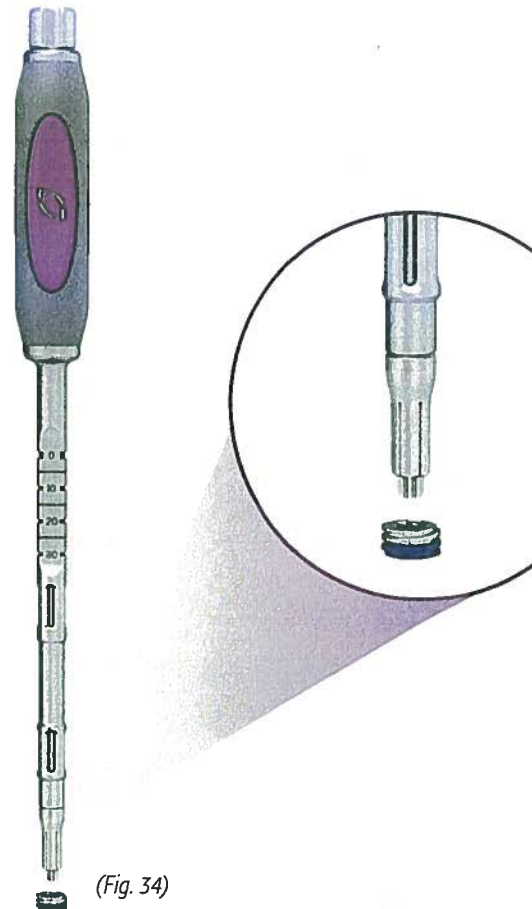

(Fig. 34)

RELINE™ – MAS™ CORE TECHNIQUE GUIDE

CORE TECHNIQUE GUIDE | SHORT CONSTRUCT | REDUCTION SCREWS

STEP 15:

REDUCTION (OPTIONAL)

Bulldozer (Primary Option)

The Bulldozer is the primary reduction option that allows up to 30mm of reduction. Use the Bulldozer at highly lordotic angles or any segment where the rod normalizing to the tulip will be challenging. This reducer is the best at normalizing the rod to the tulip.

To Reduce:

1. With the lock screw in the caddy, load the lock screw onto the distal tip of the Bulldozer.
2. Insert the Bulldozer over the Guide while lining up the lasermarks on both the Guide and Bulldozer.
3. Push the Bulldozer down (axially) until the gold tabs of the reduction housing positively engage with the top of the Guide.
4. Pull up (axially) on the handle to verify full engagement.
5. Place the reduction attachment of choice onto the reduction knob of the Bulldozer and turn clockwise until the rod is fully reduced into the tulip (Figs. 35, 35a).

Note: The reduction attachment options include the following:

- Reduction Bell Attachment
- Dual-ended Straight Handle
- Combo Tool

Reduce the middle levels and inferior/superior levels of a construct simultaneously for easier rod seating.

Use *Pile Driver* and *Bulldozer* reducers in combination during the case.

Note: Engage the silver side of the Reduction Attachment tools to the Bulldozer reducer to engage and dial in the needed amount of reduction.

6. The rod is fully reduced when the measurement window indicates "0" (Fig. 36), the gap is closed, and the green line is recessed (Fig. 36a).

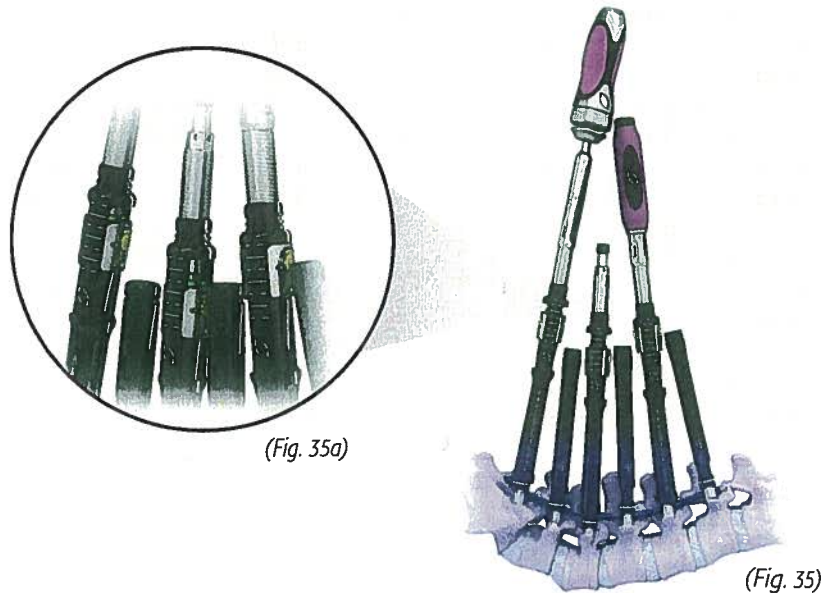

(Fig. 35a)

(Fig. 35)



(Fig. 36)

(Fig. 36a)

RELINE™ – MAS® CORE TECHNIQUE GUIDE

CORE TECHNIQUE GUIDE | SHORT CONSTRUCT | REDUCTION SCREWS

STEP 15:

REDUCTION (OPTIONAL) (CONT.)

Bulldozer (Primary Option) (Cont.)

To Deliver Lock Screw:

1. Remove the Reduction Attachment and place the lock screw attachment of choice on the lock screw knob of the Bulldozer.

- This will be indicated by the black color marker, which dictates the side of the multi-use instruments that will start the lock screw.

Note: The lock screw attachment options include the following:

- Dual-ended Straight Handle
- Combo Tool
- Quarter Square Lock Screw Attachment

2. Turn counterclockwise to align the interlocking flanges until an audible "click" is heard.
3. The "click" confirms the interlocking flanges of the tulip are aligned with the interlocking flanges of the lock screw.
4. Once the interlocking flanges are aligned, turn Lock Screw Attachment clockwise until the lock screw is delivered.

To Remove:

1. Remove the Bulldozer by turning the reduction knob counterclockwise 5mm of the reduction, and pulling up (axially) on the lock screw knob (i.e., "pull the pin") to disengage the Bulldozer from the lock screw.
 - The Guide Head Adjuster may be used to disengage the pin by inserting the engagement under the pin and pulling up (axially).
2. Depress the gold tabs of the reduction housing and remove the Bulldozer (Fig. 37).

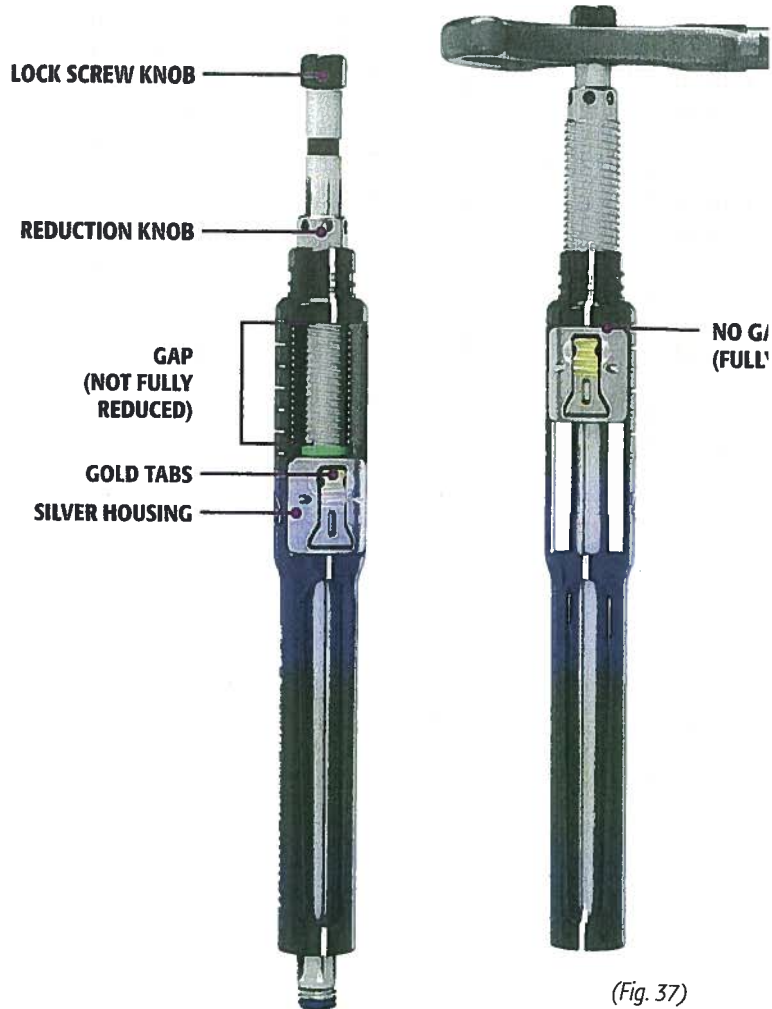

(Fig. 37)

NVM5®



Monitor for nerve disturbances (EMG) and changes in spinal cord motor (MEP) and sensory (SSEP) baselines during rod reduction, in situ rod bending, compression/distraction, and final tightening.

RELINE™ – MAS® CORE TECHNIQUE GUIDE

CORE TECHNIQUE GUIDE | SHORT CONSTRUCT | REDUCTION SCREWS

STEP 15:

REDUCTION (OPTIONAL) (CONT.)

Pile Driver (Alternative Option)

The Pile Driver is an alternative reduction option that allows up to 50mm of gradual, controlled reduction through the Guide.

To Reduce:

1. With the lock screw still in the caddy, load the lock screw onto the distal tip of the Pile Driver, ensuring the hexalobe feature protrudes through the lock screw.
2. Insert the Pile Driver through the top of the Guide, while lining up the lasermarks on both the Guide and Pile Driver, ensuring the gold tabs of the reduction housing positively engage (snap into) the Guide.
3. Pull up (axially) on the handle to verify full engagement.
4. Place the Reduction Attachment of choice, silver side down, onto the reduction knob of the Pile Driver and turn clockwise until the rod is fully reduced into the tulip (Fig. 38).
5. Rotate the Reduction Attachment clockwise until the rod is fully reduced.
 - When the green line is completely buried (Fig. 39) below the silver reduction knob, the instrument will be indicating full reduction.

Tip:

- Reduce the middle levels and inferior/superior levels of a construct simultaneously for easier rod seating.
- Use Pile Driver and Bulldozer reducers in combination during the case.

Note: if the tip of the instrument is not contacting the rod at 90°, the rod may not be fully normalized to the tulip. Ensure the tip of the instrument is contacting the rod at 90° prior to starting the lock screw with the Pile Driver.



(Fig. 38)



(Fig. 39)

RELINE™ – MAS® CORE TECHNIQUE GUIDE

CORE TECHNIQUE GUIDE | SHORT CONSTRUCT | REDUCTION SCREWS

STEP 15:

REDUCTION (OPTIONAL) (CONT.)

Pile Driver (Alternative Option) (Cont.)

To Deliver Lock Screw:

1. Remove the Reduction Attachment and place the lock screw attachment of choice, black side down, on the lock screw knob of the Pile Driver (Fig. 40).

Note: The lock screw attachment options include the following:

- Dual-ended Straight Handle
- Combo Tool
- Quarter Square Lock Screw Attachment

2. Turn counterclockwise to align the interlocking flanges until an audible “click” is heard.
3. The “click” confirms the interlocking flanges of the tulip are aligned with the interlocking flanges of the lock screw.

Tip: Ensure each Guide is perpendicular to the rod when starting the lock screw with the Pile Driver to confirm the rod is normalized. If an audible click is still not heard with the Pile Driver when starting the lock screw, remove the Pile Driver and use the Bulldozer to reduce and introduce the lock screw at the level.

4. Once the interlocking flanges are aligned, turn handle clockwise until the lock screw is delivered.
5. The lock screw knob will no longer turn when the lock screw is fully delivered.

To Remove:

1. Remove the Pile Driver by turning the reduction knob counterclockwise to back off reduction, approximately 10mm.
2. Depress the gold tabs of the reduction housing, and then pull up (axially) to remove the instrument (Fig. 41).



(Fig. 40)

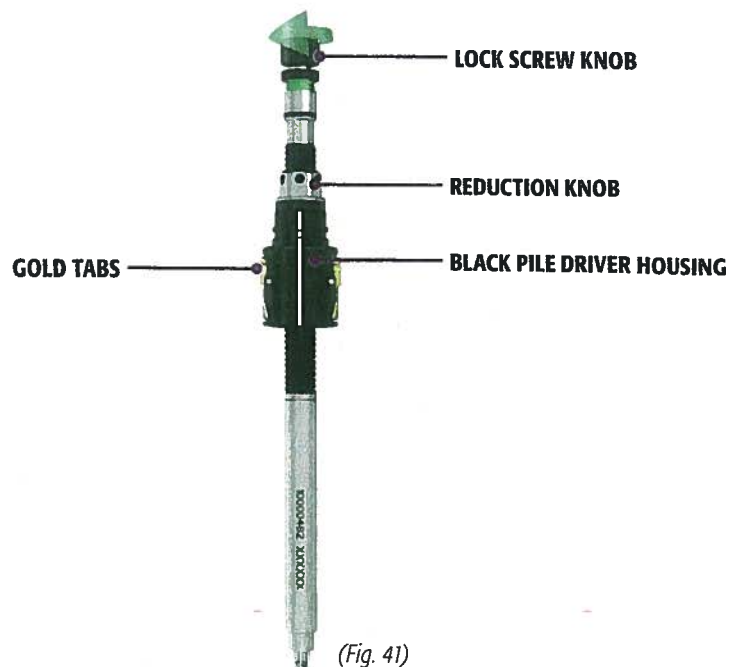

(Fig. 41)

RELINE™ – MAS® CORE TECHNIQUE GUIDE

CORE TECHNIQUE GUIDE | SHORT CONSTRUCT | REDUCTION SCREWS

STEP 16:

FINAL TIGHTENING THROUGH REDUCTION INSTRUMENTS (OPTIONAL)

If the surgeon desires, final tightening can be achieved through the Reline reduction instruments with the use of a Counter-torque, Torque T-handle, and Quarter Square Lock Screw Attachment.

Note: Ensure the rod is placed appropriately and has adequate overhang prior to final tightening.

Ensure that all levels on the construct are fully reduced and lock screws are delivered prior to final tightening through any of the reducers.

1. After full reduction has been achieved and lock screw delivered, the level can be final tightened through the reduction instrument.
2. Place the Reline Guide Counter-torque on the proximal portion of the reducer (Pile Driver or Bulldozer) by engaging the Counter-torque on the flats of the reducer (Fig. 42).

Note: In order to maintain optimal engagement to the lock screw during final tightening, apply downward axial pressure to the Torque T-handle while final tightening.

3. Once Counter-torque is engaged, attach the Torque T-handle to the Quarter Square Lock Screw Attachment. Place on the Lock Screw attachment of the reduction instrument (Fig. 42).

Note: If the tip of the instrument is not contacting the rod at 90°, the rod may not be fully normalized to the tulip. Ensure the tip of the instrument is contacting the rod at 90° prior to starting final tightening of the lock screw.

4. Turn clockwise until Torque T-handle breaks off.
5. Final tightening has been achieved on this level once the Torque T-handle breaks away.



(Fig. 42)

RELINE™ — MAS® CORE TECHNIQUE GUIDE

CORE TECHNIQUE GUIDE | SHORT CONSTRUCT | REDUCTION SCREWS

STEP 17:

COMPRESSION/DISTRACTION (OPTIONAL): USED WHEN GUIDES ARE NOT CONVERGING

Assembly

1. In the unlocked "green" position, attach the C/D Rack Bottom to the proximal portions of the Guides by engaging the attachment features and pushing until they lock into place.
2. In the "N" (neutral) position, attach the C/D Rack Top to the C/D Rack Bottom by engaging the male and female engagements and pressing down axially until they click into place.
3. Engage the Dual-ended Straight Handle Lock Screw Starter (black side) attachment or the Quarter Square Lock Screw Attachment with Ratcheting Handle to the Pinion to compress or distract.

Compression/Distraction Rack

1. WITHOUT the C/D Rack attached to the Guides, final tighten one lock screw with the Torque T-handle and Counter-torque (Fig. 43).
2. Engage the tops of the Guides with the C/D Rack, and insert a lock screw in the other Guide spanning the level to be compressed (Fig. 44). Be sure to leave this lock screw very loose to allow for translation of the rod. Ensure the C/D Rack is in the "N" (neutral) position and the lock/unlock mechanism is in the unlocked "green" position (Figs. 44a, 44b). Insert the Long Final Driver to engage the lock screw and leave in place during compression/distraction.



(Fig. 43)

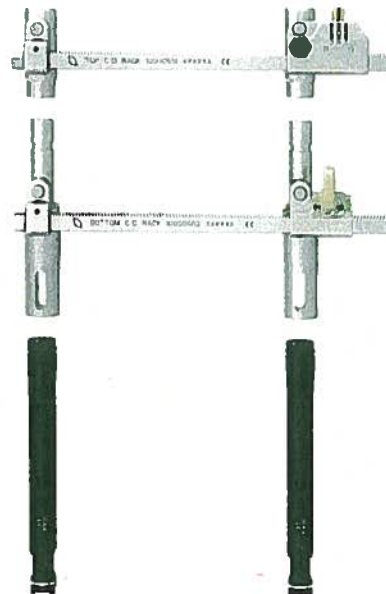
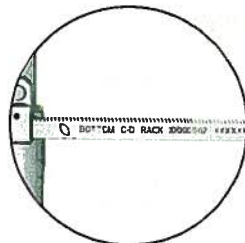
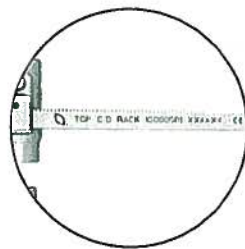

(Fig. 44)

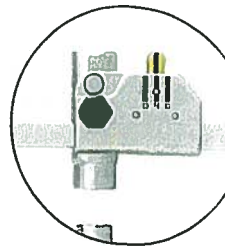

(Fig. 44a)

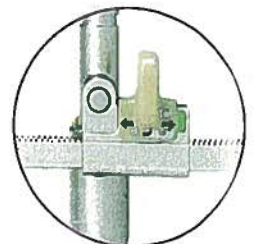

(Fig. 44b)

RELINE™ – MAS™ CORE TECHNIQUE GUIDE

CORE TECHNIQUE GUIDE | SHORT CONSTRUCT | REDUCTION SCREWS

STEP 17:

**COMPRESSION/DISTRACTION (OPTIONAL):
USED WHEN GUIDES ARE NOT CONVERGING
(CONT.)**

Compression/Distracton Rack (Cont.)

3. To compress:

Begin with Guides slightly "toed in" to each other at the top of the rack to establish your pivot point. Lock the C/D Rack Bottom by engaging the slide to the locked position (slide is to the right, and "window" is red) (Figs. 45, 45a).

Engage the indicator on the C/D Rack Top to the "C" (compression) position (Fig. 45a). Engage the Dual-ended Straight Handle lock screw attachment or Quarter Square Lock Screw Attachment with Short Straight Ratcheting Handle to the Pinion, and rotate clockwise to achieve desired compression.

4. To distract:

Begin with Guides slightly "toed out" from each other at the top of the rack to establish your pivot point. Lock the C/D Rack Bottom by engaging the slide to the locked position (slide is to the right, and "window" is red) (Figs. 46, 46a).

Engage the indicator on the C/D Rack Top to the "D" (distraction) position (Fig. 46a). Engage the Dual-ended Straight Handle or Quarter Square Lock Screw Attachment with Ratcheting Handle to the Pinion, and rotate counterclockwise to achieve desired distraction (Figs. 46, 46a).

5. Hold compression or distraction and provisionally tighten the non-final tightened lock screw, using a Ratcheting Handle and Final Driver (Figs. 45, 46).

6. Remove the entire C/D Rack assembly.

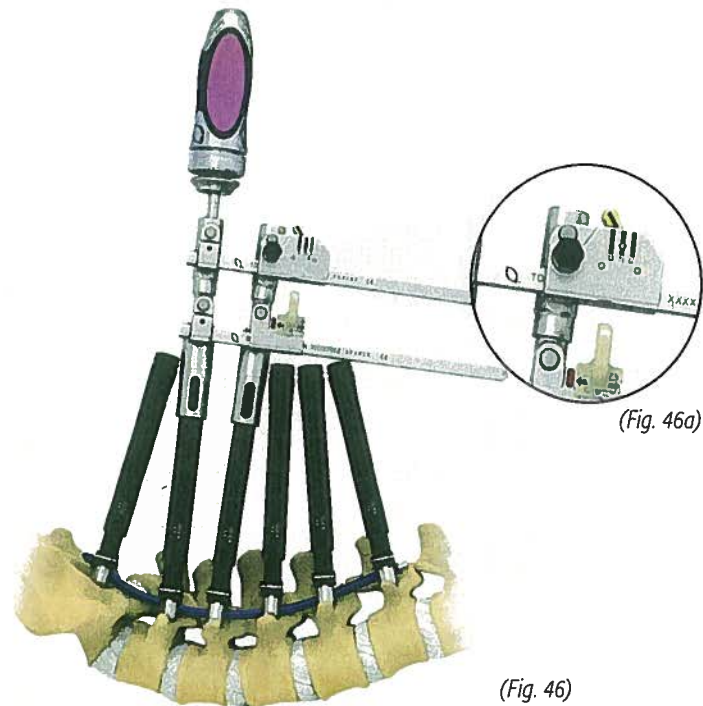
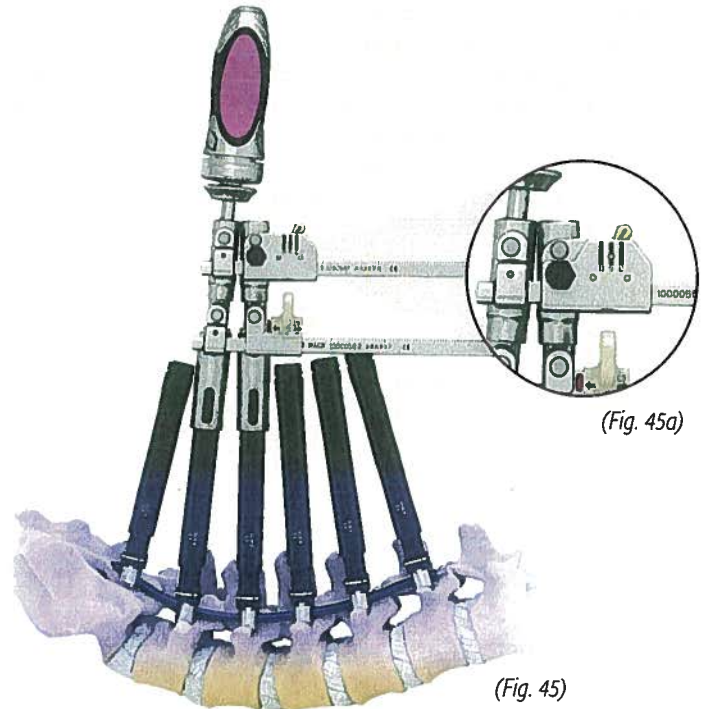

RELINE™ – MAS® CORE TECHNIQUE GUIDE

CORE TECHNIQUE GUIDE | SHORT CONSTRUCT | REDUCTION SCREWS

STEP 17:

COMPRESSION/DISTRACTION (OPTIONAL): USED WHEN GUIDES ARE NOT CONVERGING (CONT.)

Compression/Distracton Rack (Cont.)

7. Final tighten the provisionally tightened lock screw, using the Torque T-handle and Counter-torque (Fig. 47).

CAUTION

Do not final tighten through the C/D Rack, as the rod may not have the freedom to normalize to the tulip (Fig. 48).

Tip: To remove the C/D Rack, disengage the rack and release the compression lead of the instrument by turning the C/D Pinion, compressing or distracting slightly to aid in removal.



(Fig. 47)

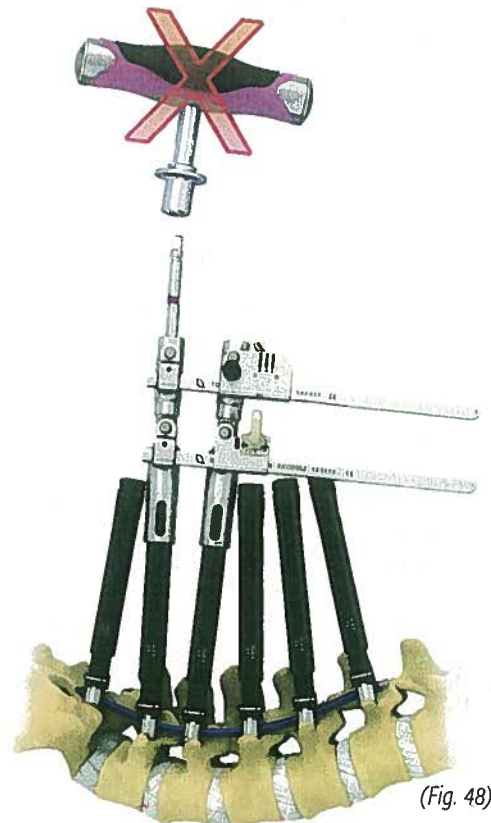

(Fig. 48)

STEP 17:

**COMPRESSION/DISTRACTION (OPTIONAL):
USED WHEN GUIDES ARE NOT CONVERGING
(CONT.)**

**Compression/Distractor Rack
with Hinged Compressor**

1. WITHOUT the C/D Rack attached to the Guides, final tighten one lock screw with the Torque T-handle and Counter-torque (Fig. 49).
2. Engage the tops of the Guides with the C/D Rack Bottom in the unlocked position, and insert a lock screw in the other Guide spanning the level to be compressed (Fig. 50). Be sure to leave this lock screw very loose to allow for translation of the rod. Insert the Long Final Driver to engage the lock screw and leave in place during compression/distractor (Fig. 50).

Note: If unable to attach the C/D Rack Bottom to the Guides for compression/distractor, the Hinged Compressor may be used with an instrument placed in-between the Guides to compress or distract, as necessary. Follow the same steps outlined below to create a pivot point.

3. To compress:

Begin with Guides slightly “toed in” to each other at the top of the rack to establish your pivot point. Lock the C/D Rack Bottom by engaging the slide to the locked position (slide is to the right, and “window” is red, as seen on page 6+ steps for C/D Rack Bottom).

Once this pivot point is determined, utilize the Hinged Compressor as close to the skin level as possible, and squeeze to drive compression (Fig. 50).



(Fig. 49)



(Fig. 50)

RELINE™ – MAS® CORE TECHNIQUE GUIDE

CORE TECHNIQUE GUIDE | SHORT CONSTRUCT | REDUCTION SCREWS

STEP 17:

COMPRESSION/DISTRACTION (OPTIONAL): USED WHEN GUIDES ARE NOT CONVERGING (CONT.)

Compression/Distracton Rack with Hinged Compressor (Cont.)

4. To distract:

Begin with Guides slightly “toed out” from each other at the top of the rack to establish your pivot point. Lock the C/D Rack Bottom by engaging the slide to the locked position (slide is to the right, and “window” is red) (Fig. 51).

Once this pivot point is determined, utilize the Hinged Compressor as close to the top of the C/D Rack Top as possible, and squeeze to drive distraction (Fig. 51).

5. Hold compression or distraction and provisionally tighten the non-final tightened lock screw, using a Ratcheting Handle and Final Driver (Fig. 51).
6. Remove the Hinged Compressor and the entire C/D Rack assembly.
7. Final tighten the provisionally tightened lock screw, using the Torque T-handle and Counter-torque (Fig. 52).

CAUTION

Do not final tighten through the C/D Rack, as the rod may not have the freedom to normalize to the tulip (Fig. 53).

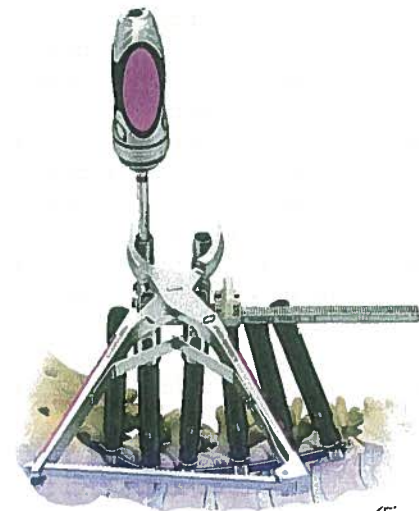

(Fig. 51)

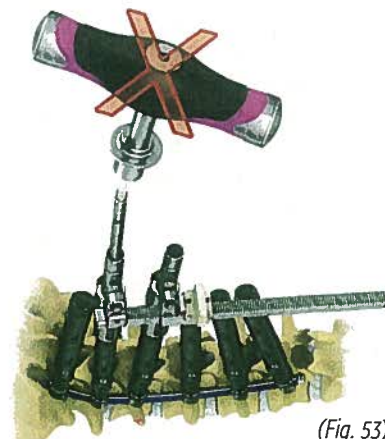

(Fig. 53)

RELINE™ – MAS' CORE TECHNIQUE GUIDE

CORE TECHNIQUE GUIDE | SHORT CONSTRUCT | REDUCTION SCREWS

STEP 18:

**COMPRESSION/DISTRACTION (OPTIONAL):
USED WHEN GUIDES ARE CONVERGING
(L5-S1 OPTION)**

**When the Surgeon Is Working
on the Ipsilateral Side**

1. Identify the Medial Guide (MEDIAL to the patient) (Fig. 54).
2. WITHOUT the Figure 8 Compressors around the Guides, final tighten one lock screw with the Torque T-handle and Counter-torque (Fig. 55).
3. Engage (but leave loose) a lock screw in the other Guide(s) spanning the level to be compressed (Fig. 56).
4. Identify Figure 8 Compressor Upper (lasermarked "Top") (Fig. 57) and Figure 8 Compressor Hinged (lasermarked "Bottom") (Fig. 58), and assemble accordingly. The Figure 8 Compressor Hinged will always be on the bottom of the assembly.
5. The Figure 8 Compressor Hinged may be in the locked position. If so, depress the button (up or down) to open up the Figure 8 Compressor Hinged and separate the handles to allow for easier attachment to the Guides. Place the Figure 8 Compressor Hinged (Bottom) at the skin level, as low as it will possibly go, to create a closer pivot point to screw heads. This may be dictated by where the Guides are converging or patient anatomy (Figs. 59, 59a).



(Fig. 54)

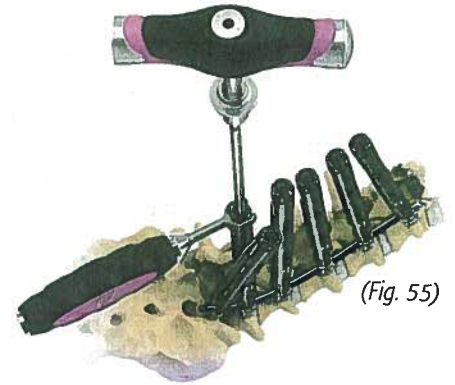

(Fig. 55)

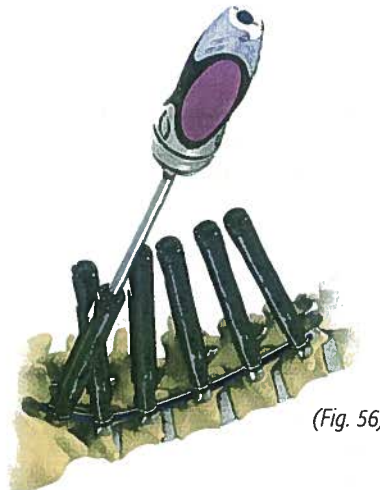

(Fig. 56)



(Fig. 57)

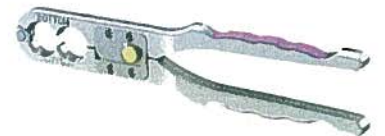

(Fig. 58)

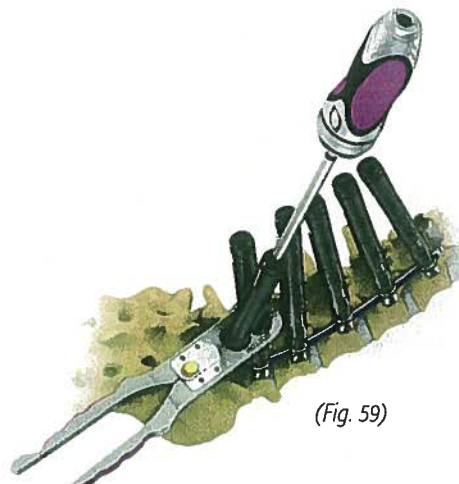

(Fig. 59)

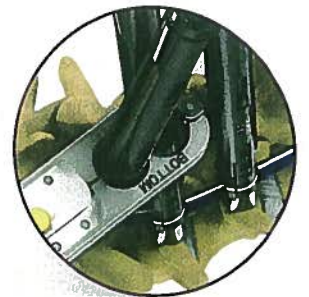

(Fig. 59a)

RELINE™ — MAS™ CORE TECHNIQUE GUIDE

CORE TECHNIQUE GUIDE | SHORT CONSTRUCT | REDUCTION SCREWS

STEP 18:

**COMPRESSION/DISTRACTION (OPTIONAL):
USED WHEN GUIDES ARE CONVERGING
(L5-S1 OPTION) (CONT.)**

**When the Surgeon Is Working
on the Ipsilateral Side (Cont.)**

6. Place the Figure 8 Compressor Upper over the top of the Guides. Position this as high as possible on the Guides (Figs. 60, 61).

Note: These two Compressors should form approximately a 90° angle when properly assembled (Fig. 61).

7. Compress (or distract) as needed by pushing the handles toward (or away from) each other to compress or distract, respectively (Fig. 61).

8. Hold compression or distraction and provisionally tighten the non-final tightened lock screw, using a Ratcheting Handle and Final Driver (Fig. 62).

9. Remove the entire Figure 8 Compressor assembly.

Tip: To remove the Figure 8 Compressor assembly, push the handles in the opposite direction of the compression or distraction technique to release the compression lead of the instrument. In addition, depress the button (in either direction) and separate the handles of the Figure 8 Compressor Hinged.

10. Final tighten the provisionally tightened lock screw, using the Torque T-handle and Counter-torque (Fig. 63).

CAUTION

Do NOT final tighten through the Figure 8 Compressor, as the rod may not have the freedom to normalize to the tulp (Fig. 64). Be cautious not to over compress or distract, as you can loosen the screws in the spine and potentially pull out the screw.

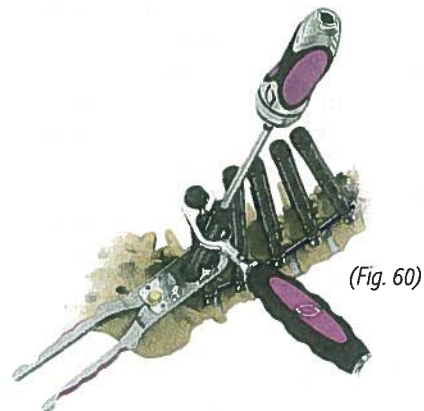

(Fig. 60)

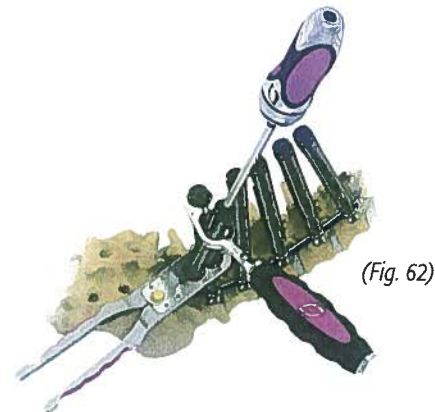
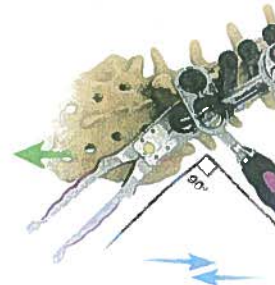

(Fig. 62)

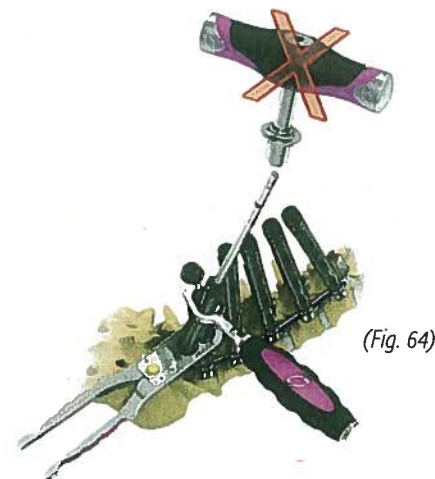

(Fig. 64)

RELINE™ – MAS® CORE TECHNIQUE GUIDE

CORE TECHNIQUE GUIDE | SHORT CONSTRUCT | REDUCTION SCREWS

STEP 19:

FINAL TIGHTENING

1. Align the flats on the Counter-torque with the flats on the top of the Guide.
2. Fully seat the Counter-torque onto the top of the Guide.
3. Insert the Final Driver with the Torque T-handle attached (Fig. 65).
4. Final tighten and remove the Final Driver, Torque T-handle, and Counter-torque.

CAUTION

All lock screws should be final tightened with the Counter-torque and Torque T-handle. Do not final tighten through compression instruments in the set, as the rod may not be able to normalize to the tulp.

OPTIONAL

Utilize NuvaMap™ O.R. to assess the lumbar lordosis (LL) achieved and its effect on sagittal alignment (P-LL) in real-time after final rod placement and prior to closing (Fig. 66).

STEP 20:

GUIDE REMOVAL

1. Insert the Guide Acorn Tool into the proximal end of the Guide.
2. Turn the Guide Acorn Tool counterclockwise until the silver castle nut is completely backed out (Fig. 67).
3. Rotate the Guide 90° to release the engagement features from the screw head.
4. Then pull up (axially) to remove the Guide.



(Fig. 65)

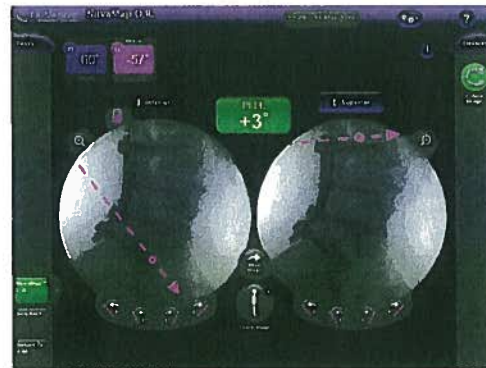

(Fig. 66)



(Fig. 67)

RELIN[™] – MAS[®] CORE TECHNIQUE GUIDE

CORE TECHNIQUE GUIDE | SHORT CONSTRUCT | REDUCTION SCREWS

STEP 21:

OPEN-TOP SLIP-ON GUIDE REMOVAL

If the Open-Top or Slip-on Guide was used, it can be removed with the Twist Guide Removal Tool:

1. Align the Removal Tool Paddle so the indents align and the black arrow mates up (Fig. 68a).
2. Advance the Removal Tool down the Guide until it is completely flush with the top of the Guide (Fig. 68).

Note: The Removal Tool indents and black arrow **MUST** be aligned to be inserted into the Guide (Fig. 68a).

3. Once the Removal Tool is inserted, turn it clockwise 180° until the Removal Tool indents and black arrow are not aligned (Fig. 69).

Note: The Removal Tool must be turned so the indents and black arrow do not mate up to engage the Guide and remove the instruments (Fig. 69a).

4. Once aligned, remove the Open-Top Guide or Slip-on Guide and Removal Tool as one piece from the screw by pulling straight back (Fig. 69).

Note: Remove all instruments as one piece (Fig. 69).

To remove the Removal Tool from the Open-Top Guide or Slip-on Guide, turn the Removal Tool Paddle counterclockwise so the indents align and black arrow mates up. Then pull the instrument apart from the Open-Top Guide or Slip-on Guide (Figs. 68a, 69a).

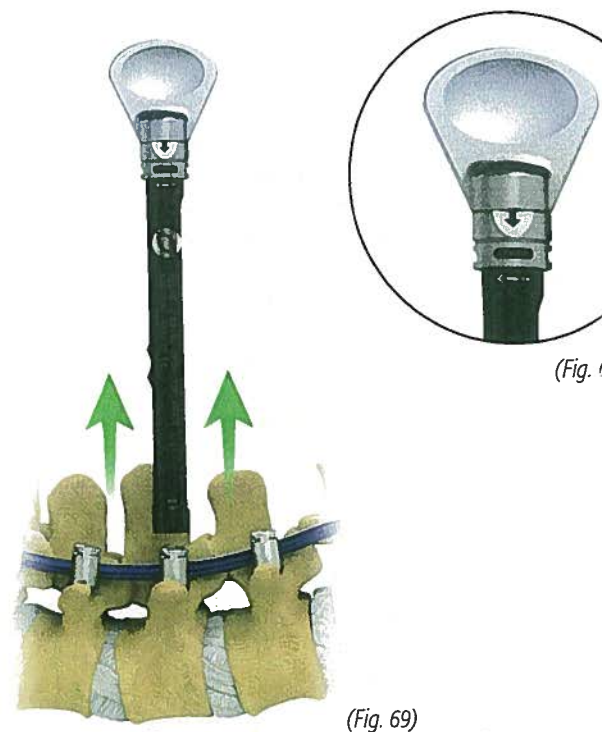
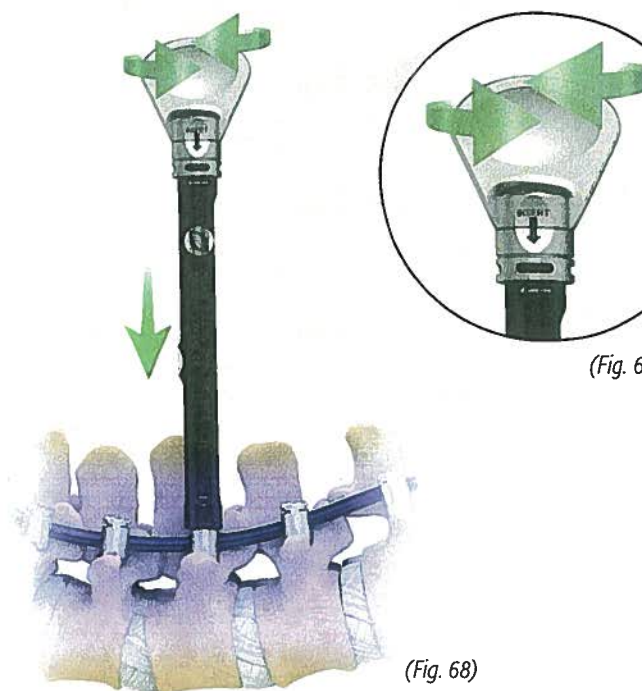

A series of horizontal lines for writing notes, spanning the width of the page.

**RELINE™ —
MAS® SHORT
CONSTRUCT
TECHNIQUE GUIDE**

RELINE™ – MAS® SHORT CONSTRUCT TECHNIQUE GUIDE

CORE TECHNIQUE GUIDE | SHORT CONSTRUCT | REDUCTION SCREWS

RELINE OPEN-TOP GUIDES OVERVIEW OF TECHNIQUE OPTIONS

There are two technique options which will be explored in this section. This is specifically for one-level and two-level constructs.

One-Level Technique – Standard

The Reline Open-Top Guides one-level technique will always utilize two Open-Top Guides, back-to-back.

- The metal bridge on a One-Level Guide is lower to allow for a maximum 35mm rod to be inserted subfascial.
- Indicating arrows will always face in the same direction.
- The Rod Inserter will always dissect both Open-Top Guides, “splitting the field goal posts.”

Two-Level Technique – Standard

The Reline Open-Top Guides two-level technique will always utilize two Open-Top Guides, back-to-back, and one standard Guide at the end of the construct.

- The metal bridge on a two-level Guide is higher to allow for a maximum 65mm rod to be inserted subfascially.
- Indicating arrows will always face in the same direction.
- The Rod Inserter will always dissect both Open-Top Guides, while the standard Guide is kicked out of plane.

ONE-LEVEL TECHNIQUE

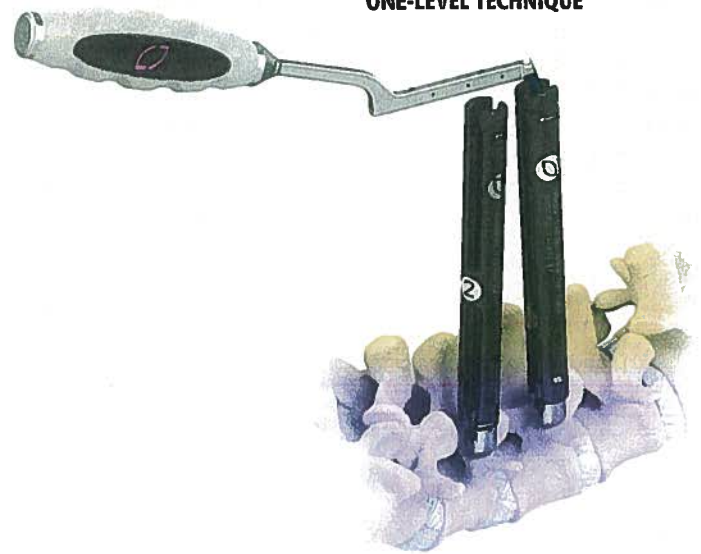

TWO-LEVEL TECHNIQUE



RELINE™ – MAS® SHORT CONSTRUCT TECHNIQUE GUIDE

CORE TECHNIQUE GUIDE | SHORT CONSTRUCT | REDUCTION SCREWS

Before following the instructions to this Reline Open-Top Guides technique, review the first seven steps outlined on pages 41-49 in the Reline MAS® CORE technique.

One-Level Technique – Standard

STEP 1:

OPEN-TOP GUIDE SCREW PLACEMENT

Load a screw onto the One-Level Open-Top Guide (Fig. 1).

For Open-Top Guide loading of screws, screws MUST be loaded in the Open-Top Guide Screw Caddy in the CORE Implant tray.

Loading the Screw

1. Remove the appropriately selected screw size from the Polyaxial Screw Caddy and insert into the Open-Top Guide Screw Caddy.
2. Place the Open-Top Guide over the screw in the caddy and press down until it clicks into place and a rigid engagement is achieved (Fig. 2).

Screw Insertion

1. Insert the One-Level Guide at the rod insertion level (Fig. 3), which is a metal bridge with the number "1."
2. Insert the Two-Level Guide at the adjacent level.
3. Prior to rod insertion, orient the insertion Open-Top Guide with the arrows and the metal bridge facing the construct (i.e., facing the other Guide).

Note: The Guide Head Adjuster may be used to help align the Open-Top Guides. Refer to the MAS CORE technique for step-by-step instructions on aligning the Open-Top Guide rod windows.



(Fig. 1)

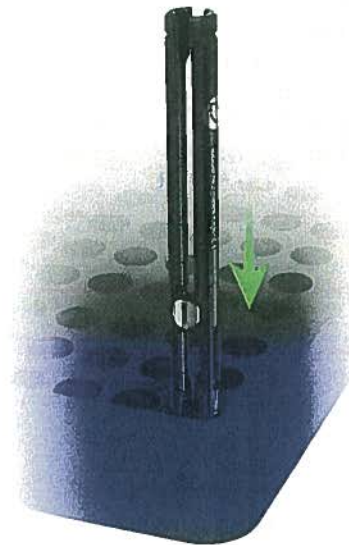

(Fig. 2)

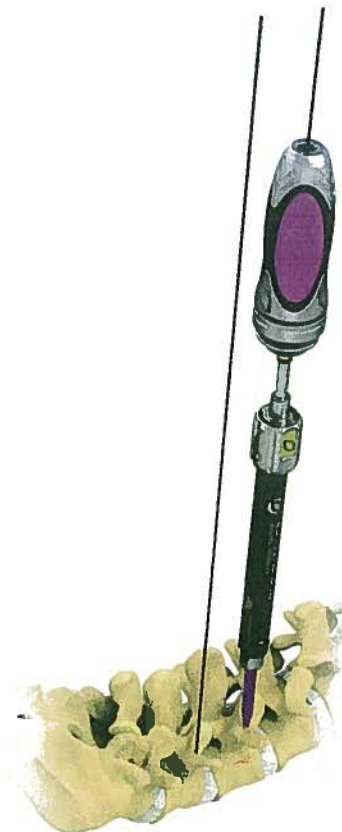

(Fig. 3)

RELINE™ – MAS® SHORT CONSTRUCT TECHNIQUE GUIDE

CORE TECHNIQUE GUIDE | SHORT CONSTRUCT | REDUCTION SCREWS

One-Level Technique – Standard (Cont.)

STEP 2:

ROD INSERTION (FIXED OBTUSE ROD INSERTER)

1. With the rod facing down the Guide, advance the handle of the Rod Inserter through both Open-Top Guides (“splitting the field goal posts”) while staying in plane with the rod slots.
2. The heel of the inserter can be inside of the Open-Top Guide as the rod is being placed (Fig. 4).

Note: Only the Fixed Obtuse Rod Inserter will fit down the Open-Top Guides. All other Rod Inserters must use conventional rod passing techniques. (See Reline MAS® CORE technique for step-by-step instructions on use.)

3. Once the bulletted portion of the rod is subfascial, advance the rod, so the heel of the inserter is within the Guide.
4. When the heel of the inserter is subfascial, fully seat the rod, so the heel of the inserter is outside of the Guide (Fig. 5).

Note: The inserter is still attached to the rod at this point. If required, use the metal bridge of the Guide to pivot and drive the heel of the inserter out of the Guide. Take a lateral fluoroscopy image to confirm the entire inserter is sitting outside of the Guide.

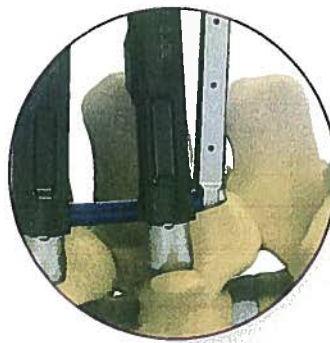

RELINE™ – MAS® SHORT CONSTRUCT TECHNIQUE GUIDE

CORE TECHNIQUE GUIDE | SHORT CONSTRUCT | REDUCTION SCREWS

Two-Level Technique – Standard

STEP 1:

OPEN-TOP GUIDE SCREW PLACEMENT

1. Insert the Two-Level Guide at the insertion level (metal bridge with the number “2”).
2. Place a One-Level Guide at the middle level.
3. Insert a standard Guide at the last level (Fig. 6).
4. Adjust the insertion Open-Top Guide with the arrows and the metal bridge facing the construct (i.e., facing the other Guides).

STEP 2:

ROD INSERTION (FIXED OBTUSE ROD INSERTER)

Note: The Adjustable Rod Inserter is not designed for the Open-Top Guides technique; use only the Fixed Obtuse Rod Inserter.

1. With the rod facing down the superior Guide, advance the handle of the inserter through both Open-Top Guides (“splitting the field goal posts”) while staying in plane with the rod slots.
2. Move the standard Guide out of plane as depicted (Fig. 7).

Note: For a two-level construct, orient the standard Guide out of plane while splitting the two Open-Top Guides with the inserter (Fig. 7).

3. The heel of the inserter can be inside of the Open-Top Guide as the rod is being placed (Fig. 7).
4. Once the bullet portion of the rod is subfascial, advance the rod so the heel of the inserter is within the Guide (Fig. 8).
5. When the heel of the inserter is subfascial, fully seat the rod, so the heel of the inserter is outside of the Guide.

Note: The inserter is still attached to the rod at this point. If required, use the metal bridge of the Guide to pivot and drive the heel of the inserter out of the Guide. Take a lateral fluoroscopy image to confirm the entire inserter is sitting outside of the Guide.



(Fig. 6)

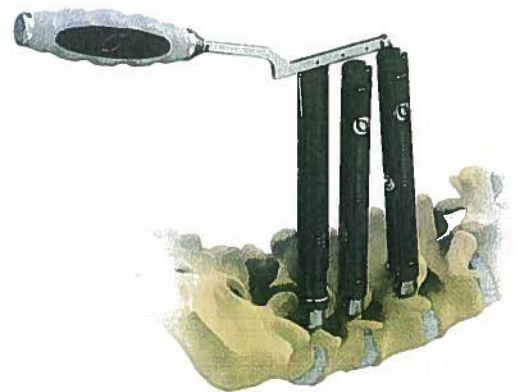

(Fig. 7)

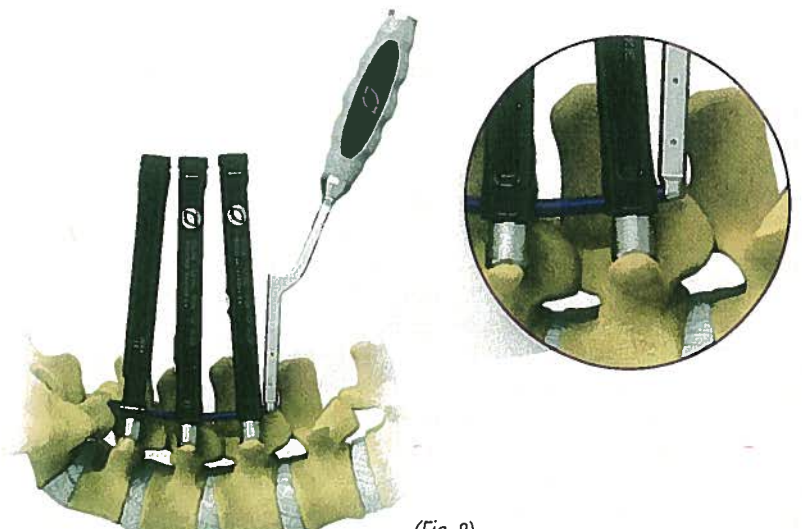

(Fig. 8)

RELINE™ – MAS® SHORT CONSTRUCT TECHNIQUE GUIDE

CORE TECHNIQUE GUIDE | SHORT CONSTRUCT | REDUCTION SCREWS

Two-Level Technique – Standard (Cont.)

STEP 3: REDUCTION

1. Match the gold tabs on the reduction instrument with the engagement features on the proximal side of the Open-Top Guide. (Orientation of the gold tabs is critical to ensure secure engagement to the Guide.)
2. Once the Pile Driver or Bulldozer reducer is attached, continue using the instrument, following the steps outlined in the Reline MAS® CORE technique (Fig. 9).

STEP 4: COMPRESSION/DISTRACTION (OPTIONAL)

Use of the Reline CORE compression/distraction instrumentation and techniques may be utilized with Open-Top Guides.

Prior to using Reline MAS Core Compression/distraction instrumentation with Open-Top Guides, insert a Short Final Driver into the final tightened fulcrum level. Then insert a Long Final Driver into the adjacent level spanning the construct to be compressed/distacted. Please refer to the Reline MAS CORE technique for step-by-step instructions on use with the Open-Top Guides.

STEP 5: FINAL TIGHTENING

1. Place the Counter-torque over the Open-Top Guide and advance down, with the arrows facing the patient (Fig. 10a).
2. Place the Counter-torque as close as possible to the distal end of the Guide.
3. Slightly turn the Counter-torque until there is some resistance (Fig. 10).
4. Final tighten with the Torque T-handle and Final Driver.

STEP 6: OPEN-TOP GUIDE REMOVAL

To remove the Open-Top Guides from the tulips, please follow the same steps outlined in the MAS CORE technique for step-by-step instructions.



(Fig. 9)



(Fig. 10)

**RELINE™ —
MAS® REDUCTION
SCREW TECHNIQUE
GUIDE**

RELINE™ – MAS® REDUCTION SCREW TECHNIQUE GUIDE

CORE TECHNIQUE GUIDE | SHORT CONSTRUCT | REDUCTION SCREWS

When using Reline MAS® Reduction Screws, refer to the MAS CORE technique for step-by-step instructions prior to rod insertion.

STEP 1: ROD INSERTION

Prior to rod insertion, align the screws in the proper orientation by using the Reline MAS Extension Alignment Tool.

To Use:

1. Align the engagement features on the Reline MAS Extension Alignment Tool with the openings above the rod slots of the MAS Reduction Screw (Fig. 1).
2. Insert the Reline MAS Extension Alignment Tool into the proximal end of the MAS Reduction Screw until a rigid engagement is achieved (Fig. 1).

Note: The Reline MAS Extension Alignment Tool can also be used to verify if the rod has passed through each level successfully by turning the Extension Alignment Tool left/right during rod passage. If the rod has passed through that level, the reduction screw will not rotate 360°.

Refer to the Reline MAS CORE technique for step-by-step instructions on rod insertion (Fig. 3).

STEP 2: SPLITTING THE TOP FOR ROD PASSAGE (OPTIONAL)

Prior to rod insertion, utilize the Reduction Screw Splitting Tool to split the top. Simply place the distal end of the tool into the middle of the screw and squeeze. Both Reduction Extensions will break at the top (Fig. 2).

Note: Ensure the Reduction Screw Splitting Tool handles are perpendicular to the rod slots before splitting the Reduction Extensions at the proximal end of the screw.

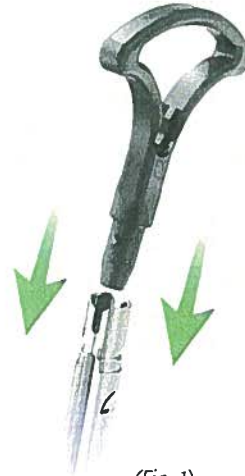

(Fig. 1)

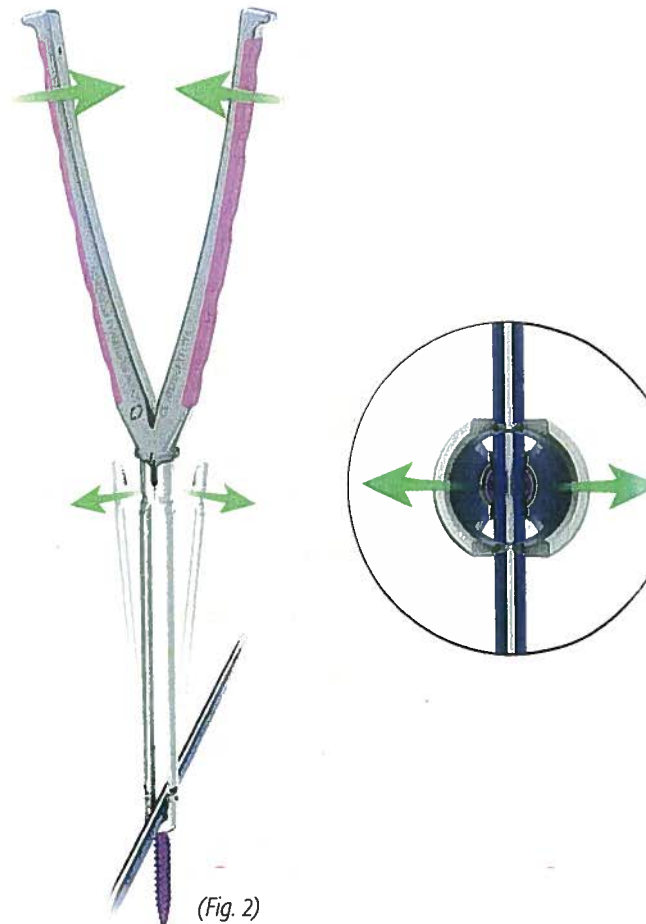

(Fig. 2)

RELINE™ – MAS® REDUCTION SCREW TECHNIQUE GUIDE

CORE TECHNIQUE GUIDE | SHORT CONSTRUCT | REDUCTION SCREWS

STEP 3:
LOCK SCREW INSERTION

Deliver the lock screws through the Reline MAS® Reduction Screws until the 0mm marking on the shaft of the Lock Screw Starter are aligned with the proximal end of the reduction screw (Fig. 3).

Note: If the Reduction Extensions were split at the top, then it is necessary to place the Reline MAS Reduction Counter-torque over the Reduction Extensions prior to starting the lock screw (Fig. 4). Gently squeeze the Reduction Extensions together with your fingers and slide the Counter-torque over the Reduction Extensions to start the lock screws (Fig. 5).



(Fig. 3)

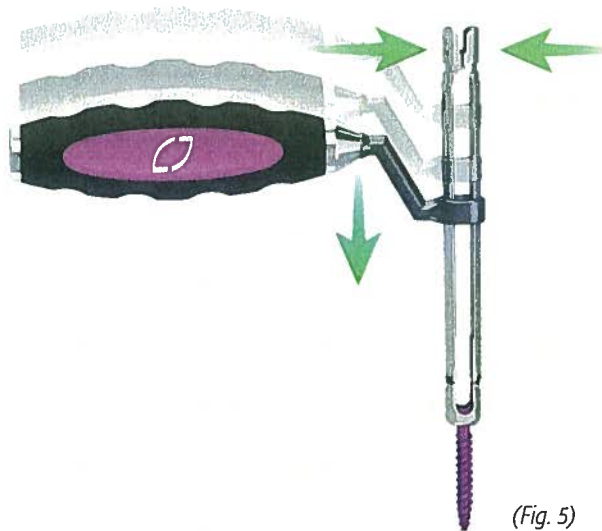

(Fig. 5)



(Fig. 4)

RELINE™ – MAS® REDUCTION SCREW TECHNIQUE GUIDE

CORE TECHNIQUE GUIDE | SHORT CONSTRUCT | REDUCTION SCREWS

STEP 4: RELINE MAS® REDUCTION BULLDOZER REDUCTION (OPTIONAL)

Note: When using the Bulldozer or Pile Driver for additional reduction needs, the lock screw will stop at the top of the built-in threads during rod reduction.

There are two technique options for delivering reduction with the Bulldozer:

A) Reduce using the reduction knob to close the window gap and bury the green line which uses the instrument to deliver the remaining reduction (this is the recommended technique).

OR

B) Reduce the window to the white bands, then utilize the lock screw knob to deliver the remaining reduction via the lock screw.

If additional reduction, beyond the 15mm of built-in reduction, is needed, the Reline MAS Reduction Bulldozer reducer can be used for up to 30mm of total reduction.

1. With the lock screw in the caddy, load the lock screw onto the distal tip of the Bulldozer.
2. Back off the reduction housing so it aligns with the 30mm lasermarked line.
3. Align the rod slot of the Bulldozer with the rod slot of the Reline MAS Reduction Screw.
4. Engage the Reline MAS Reduction Bulldozer to the top of the reduction screw by sliding the Bulldozer over the top of the reduction screw and pressing down (axially) until a positive engagement is achieved.
5. Pull up (axially) once Bulldozer is attached, to confirm proper engagement (Fig. 6).

Note: The windows of the Bulldozer should align with the Reduction Extensions of the reduction screw for proper engagement (Fig. 7).

To Use

To Reduce:

1. Once Bulldozer is engaged, attach a Ratcheting Handle to the Reduction Bell Attachment.
2. Slide over top of the Bulldozer until the engagements mate.
3. Turn clockwise until full reduction has been delivered and green line is buried (Fig. 7).

Note: Full reduction is achieved once the gap is fully closed on the Bulldozer (Fig. 8). The Dual-ended Straight Handle may also be used to drive reduction and lock screws.



(Fig. 6)



RELINE™ – MAS® REDUCTION SCREW TECHNIQUE GUIDE

CORE TECHNIQUE GUIDE | SHORT CONSTRUCT | REDUCTION SCREWS

STEP 4:
RELINE MAS® REDUCTION PILE DRIVER
REDUCTION (OPTIONAL)

To Deliver Lock Screw:

Once reduction is achieved and within the white bands of the Bulldozer, the lock screw can be delivered.

1. Attach the Quarter Square Lock Screw Attachment to a Ratcheting Handle and engage the proximal hex end of the Bulldozer.
2. Turn counterclockwise until the threads of the lock screw drop into the threads of the reduction extensions, then turn clockwise until the black line is buried. (Fig. 8)

If additional reduction, beyond the 15mm of built-in reduction, is needed, the Reline MAS Reduction Pile Driver Reducer can be used for up to 65mm of total reduction.

To Reduce:

1. Place the Reduction Screw Counter-torque over the reduction screw closest to the skin. This is necessary to provide the Counter-torque force when delivering reduction and the lock screw.
2. With the lock screw still in the caddy, load the lock screw onto the distal tip of the Pile Driver, ensuring the hexalobe feature protrudes through the lock screw.
3. Align the lasermarked lines of the Pile Driver with the rod slot of the Reline MAS Reduction Screw.
4. Engage the Reline MAS Reduction Pile Driver to the top of the reduction screw by sliding the Pile Driver over the top of the reduction screw and pressing down (axially) until a positive engagement is achieved.
5. Pull up (axially) once the Pile Driver is attached, to confirm positive engagement.
6. Select the reduction attachment of choice and reduce the rod by rotating clockwise until the green line is buried while simultaneously using the Counter-torque to resist torsion from reduction (and to ensure torque is not transmitted to the spine).
7. Once the green line is buried, the lock screw will be on top of the reduction threads and can be delivered by utilizing the lock screw attachment of choice and rotating the lock screw knob counterclockwise until an audible click is heard, then deliver your lock screw by turning clockwise. Rotate the lock screw knob until the lock screw is fully delivered through the 15mm of threads and can no longer turn. The Pile Driver and Counter-torque can now be removed from the screw.



(Fig. 8)

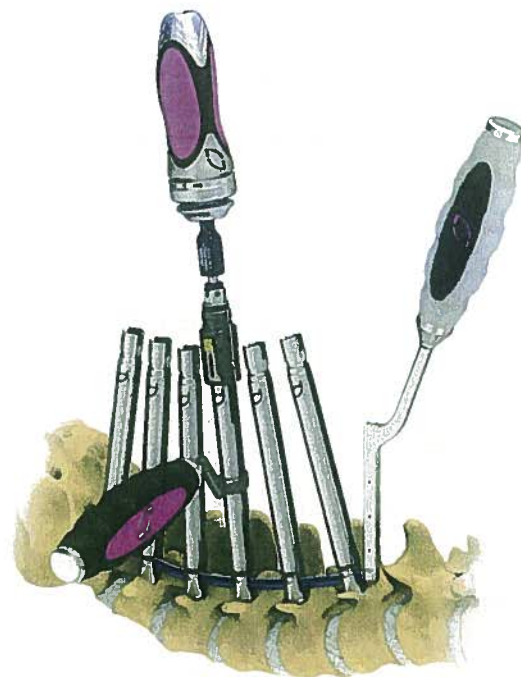

(Fig. 9)

RELINE™ – MAS® REDUCTION SCREW TECHNIQUE GUIDE

CORE TECHNIQUE GUIDE | SHORT CONSTRUCT | REDUCTION SCREWS

**STEP 5:
COMPRESSION/DISTRACTION**

If compression or distraction is desired, the Reline MAS® Reduction Screw C/D Sleeves or Figure 8 Counter-torque Sleeves can be utilized.

1. Prior to attaching any of the Compressors, slide the sleeves over both screws at the levels of desired compression or distraction.
2. Insert a Short Final Driver into the final tightened fulcrum level. Then insert a Long Final Driver into the adjacent level spanning the construct to be compressed/distracted.

Note: If the C/D Rack is desired, utilize the Reduction Screw C/D Sleeves, and place both over each screw at the level of desired correction.

Note: In order to attach the Reline MAS Reduction Screw C/D Rack Bottom to the reduction screws, depress and hold the gold wings of the C/D Rack Bottom during attachment and press down into place. Once the C/D Rack Bottom is attached, pull up on the C/D Rack to ensure proper engagement to the reduction screw.

Note: If the Figure 8 or the Hinged Compressors are desired, utilize the Figure 8 Counter-torque Sleeves.

Then follow the same steps of compression/distraction as stated in the Reline MAS CORE technique (Figure 8 Compressor and C/D Rack).



(Fig. 10)

RELINE™ – MAS® REDUCTION SCREW TECHNIQUE GUIDE

CORE TECHNIQUE GUIDE | SHORT CONSTRUCT | REDUCTION SCREWS

**STEP 6:
FINAL TIGHTENING AND
REDUCTION EXTENSIONS BREAK-OFF**

To Final Tighten:

1. Place the Reduction Screw Final Tightening Counter-torque over the top of the Reline MAS Reduction Screw (Fig. 12).
2. Insert the Final Driver with Torque T-handle attached and engage the lock screw.
3. Align the flats of the Counter-torque with the flats of the reduction screw.
4. Slide down as close as possible to the patient's skin (Fig. 11).
5. Turn the Lock Screw Driver clockwise until you hear a click (90 in-lbs) to final tighten (Fig. 11).

To Break Off Reduction Extensions:

1. Insert the MAS® Reduction Screw Splitting Tool into the proximal portion of the Reline MAS Reduction Screws, following the same steps outlined in Step 2 on page 82.
2. Squeeze the Reduction Screw Splitting Tool Handles until the screw splits at the top.
3. Repeat until all Reduction Extensions are split at the top.
4. Grab both Reduction Extensions and pull medial first, then lateral, until both Reduction Extensions are removed from the screw.

Note: Check both Reduction Extensions after removal for the black lasermark at the distal end of the Reduction Extension to ensure the Reduction Extension has broken off at the correct spot (Fig. 12).

Note: Be sure the lock screw is fully seated and the rod is fully reduced prior to breaking off the Reduction Extensions.

CAUTION

Be careful when palpating the break point as the tulip may be sharp.

Slip-on Guide Attachment/Removal (Optional): Refer to CORE technique for steps

If a Reduction Extension should prematurely break prior to final tightening, please follow steps in the Reline MAS CORE technique for attachment and removal of the Slip-on Guides.

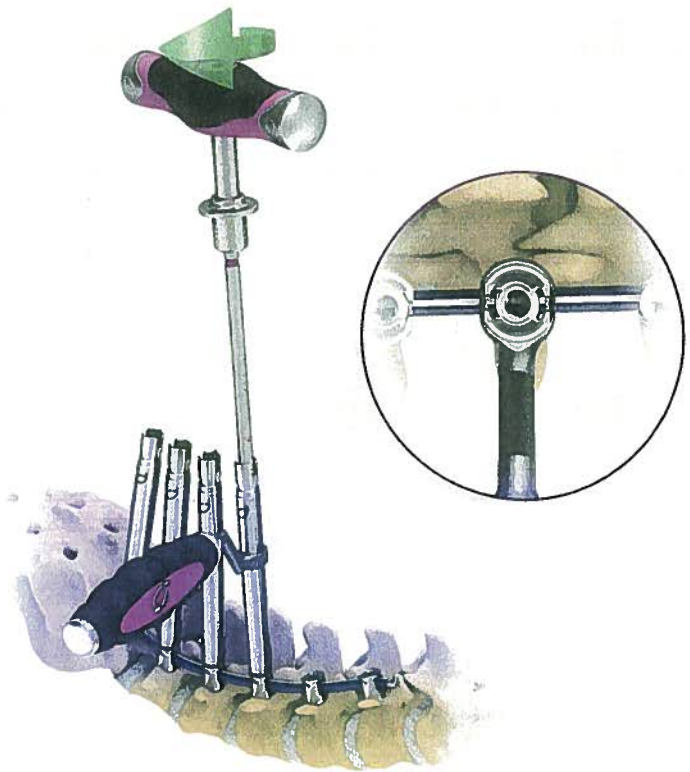

(Fig. 11)



(Fig. 12)

IMPLANT REMOVAL

IMPLANT REMOVAL

Cross Connector Removal

1. To remove the fixed or low-profile adjustable cross connector, attach the Cross Connector 40 in-lb Torque T-handle to the Cross Connector Driver (T20).
2. If removing the low-profile adjustable cross connector, first loosen the center lock screw by turning the driver counterclockwise.
3. Loosen connection to the rod by inserting the driver into the cam above each rod and rotating it counterclockwise 180°.
4. Once both cams have been unlocked, grasp the cross connector with Cross Connector Holder and lift up to remove.

Lock Screw Removal (T27)

1. Seat the Open Screw Counter-torque over the screw tulip. With a Ratcheting T-handle attached to a Lock Screw Driver, insert the instrument through the Counter-torque until it is securely seated in the lock screw. Turn the driver counterclockwise to loosen the lock screw. Repeat on the remaining screws.
2. The lock screws in the rod-rod connectors are also T27, and may be removed using the same technique.

Rod and/or Rod-to-Rod Connector Removal

Once all the lock screws have been removed from the tulips, grasp the rod with a Rod Holder and lift up to remove it from the screw heads.

Screw Removal (C-Star25 or T25)

Insert the tip of the appropriate screwdriver into the head of the screw and secure into position by turning the silver knob clockwise to thread into the tulip. Remove the screw by rotating the screwdriver handle counterclockwise. If it is preferred, the Screw Adjuster may be used by inserting it into the shaft of the screw and turning counterclockwise to remove. To remove the provisional locking screw, insert the Fixed Screwdriver into the head of the screw and secure into position by threading the outer sleeve into the tulip. Rotate the Fixed Screwdriver counterclockwise in an orbital motion to remove.

Hook Removal

Grasp the hook with an Implant Holder and slide in a cephalad or caudal direction to remove.

RELINE™ SYSTEM

RELINE™ SYSTEM – OPEN

OPEN SYSTEM | MAS® SYSTEM

RELINE CORE INSTRUMENT TRAY 1

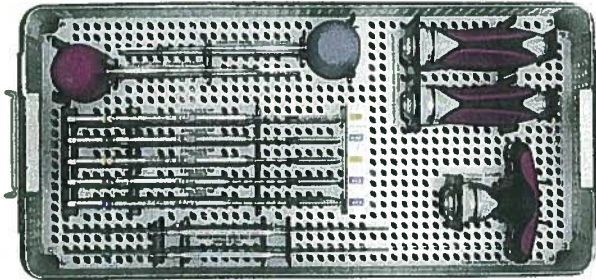

Reline Core Instrument Tray 1 – Top Level

MATERIAL DESCRIPTION	MATERIAL NUMBER	QTY
Reline Gearshift Probe, Thoracic Curved	10000613	1
Reline Gearshift Probe, Lumbar Straight	10000612	1
Reline Tap, 4.0mm Solid	10000624	1
Reline Tap, 4.5mm Solid	10000625	1
Reline Tap, 5.5mm Solid	10000627	1
Reline Tap, 6.5mm Solid	10000629	1
Reline Tap, 7.5mm Solid	10000631	1
Reline Pedicle Probe, Dual Ball Tip	10000610	2
NuVasive® Handle, Straight Long Ratchet	10000600	2
NuVasive T-handle, Ratchet	10000604	1

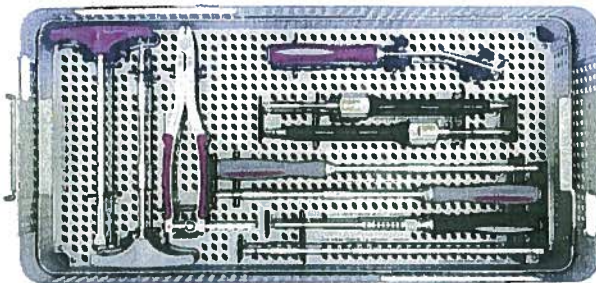

Reline Core Instrument Tray 1 – Middle Level

MATERIAL DESCRIPTION	MATERIAL NUMBER	QTY
Reline Head Adjuster	10000680	1
Reline Shank Adjuster, Solid	10000718	1
Reline Rod Holder, Open	10000700	1
Reline Joystick, Head Adjuster	10000681	1
Reline Screwdriver, Poly Solid	D10000801	2
Reline Lock Screw Starter	10000746	2
Reline Lock Screw Starter, Multi	10000707	1
Reline Lock Screw Starter, 1/4" Sq Long	10000747	1

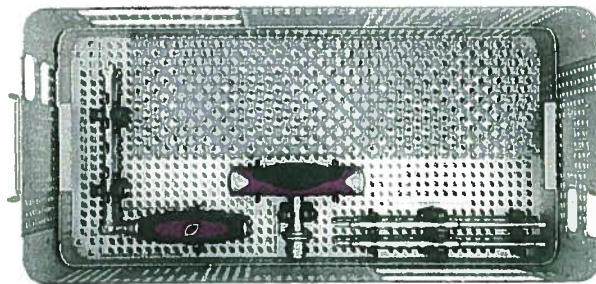

Reline Core Instrument Tray 1 – Bottom Level

MATERIAL DESCRIPTION	MATERIAL NUMBER	QTY
Reline Counter-torque, Open Screws	10000688	1
NuVasive T-handle, 90 in-lb Torque	10000606	1
Reline Final Lock Screw Driver	10000751	2

RELINE™ SYSTEM – OPEN

OPEN SYSTEM | MAS® SYSTEM

RELINE CORE INSTRUMENT TRAY 2

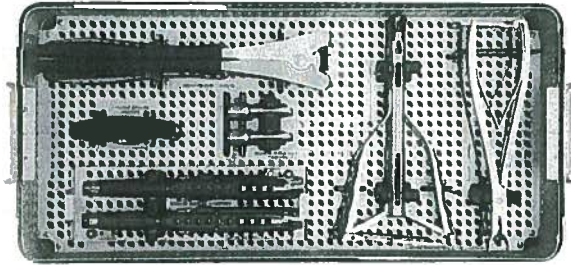

Reline Core Instrument Tray 2 – Top Level

MATERIAL DESCRIPTION	MATERIAL NUMBER	QTY
Reline French Bender	10000726	1
Reline T-handle, Reducer	10000769	1
Reline Reduction Bell, Short	10000493	2
Reline Reducer, Silencer	D10000685	2
Reline Reducer, Matador	10000779	1
Reline Rocker, Articulating	10000682	1

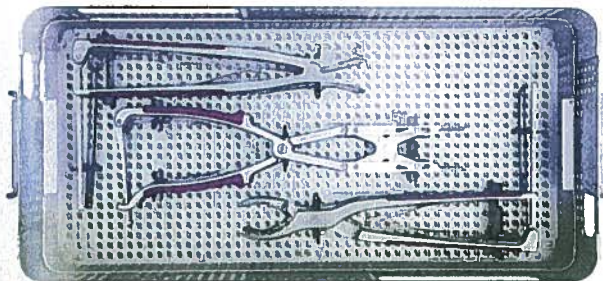

Reline Core Instrument Tray 2 – Bottom Level

MATERIAL DESCRIPTION	MATERIAL NUMBER	QTY
Reline Distractor, Hinged	10000756	1
Reline Compressor, Parallel	10000754	1
Reline Compressor, Hinged	10000752	1

RELINE™ SYSTEM – OPEN

OPEN SYSTEM | MAS® SYSTEM

RELINE CORE IMPLANT TRAY

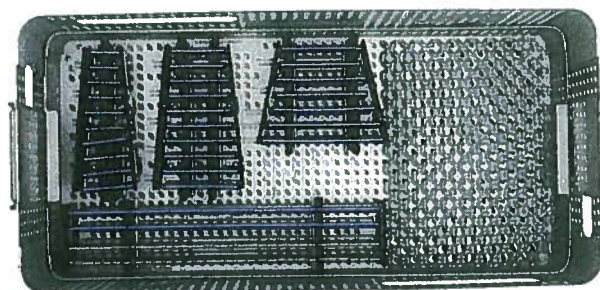
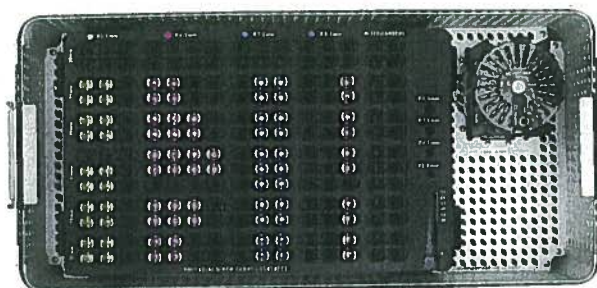

Reline Core Implant Tray – Top Level

MATERIAL DESCRIPTION	MATERIAL NUMBER	QTY
Reline Screw, 5.5x35mm 2S Polyaxial	13015535	4
Reline Screw, 5.5x40mm 2S Polyaxial	13015540	4
Reline Screw, 5.5x45mm 2S Polyaxial	13015545	4
Reline Screw, 5.5x50mm 2S Polyaxial	13015550	4
Reline Screw, 5.5x55mm 2S Polyaxial	13015555	4
Reline Screw, 6.5x35mm 2S Polyaxial	13016535	4
Reline Screw, 6.5x40mm 2S Polyaxial	13016540	6
Reline Screw, 6.5x45mm 2S Polyaxial	13016545	8
Reline Screw, 6.5x50mm 2S Polyaxial	13016550	6
Reline Screw, 6.5x55mm 2S Polyaxial	13016555	4
Reline Screw, 7.5x35mm 2S Polyaxial	13017535	4
Reline Screw, 7.5x40mm 2S Polyaxial	13017540	4
Reline Screw, 7.5x45mm 2S Polyaxial	13017545	6
Reline Screw, 7.5x50mm 2S Polyaxial	13017550	4
Reline Screw, 7.5x55mm 2S Polyaxial	13017555	4
Reline Screw, 8.5x35mm 2S Polyaxial	13018535	2
Reline Screw, 8.5x40mm 2S Polyaxial	13018540	2
Reline Screw, 8.5x45mm 2S Polyaxial	13018545	2
Reline Screw, 8.5x50mm 2S Polyaxial	13018550	2
Reline Screw, 8.5x55mm 2S Polyaxial	13018555	2
Reline, 5.5mm Lock Screw	13550000	20

Reline Core Implant Tray – Bottom Level

MATERIAL DESCRIPTION	MATERIAL NUMBER	QTY
Reline Ti Rod, 5.5x30mm Lordotic	14355030	4
Reline Ti Rod, 5.5x35mm Lordotic	14355035	4
Reline Ti Rod, 5.5x40mm Lordotic	14355040	4
Reline Ti Rod, 5.5x45mm Lordotic	14355045	4
Reline Ti Rod, 5.5x50mm Lordotic	14355050	4
Reline Ti Rod, 5.5x55mm Lordotic	14355055	4
Reline Ti Rod, 5.5x60mm Lordotic	14355060	4
Reline Ti Rod, 5.5x65mm Lordotic	14355065	4
Reline Ti Rod, 5.5x70mm Lordotic	14355070	4
Reline Ti Rod, 5.5x75mm Lordotic	14355075	4
Reline Ti Rod, 5.5x80mm Lordotic	14355080	4
Reline Ti Rod, 5.5x90mm Lordotic	14355090	4
Reline Ti Rod, 5.5x100mm Lordotic	14355100	2
Reline Ti Rod, 5.5x110mm Lordotic	14355110	2
Reline Ti Rod, 5.5x120mm Lordotic	14355120	2
Reline Ti Rod, 5.5x300mm Straight	15355300	4
Reline CoCr Rod, 5.5x300mm Straight	15455300	4

RELINE™ SYSTEM – OPEN

OPEN SYSTEM | MAS® SYSTEM

RELINE 5.5mm CROSS CONNECTOR IMPLANT TRAY

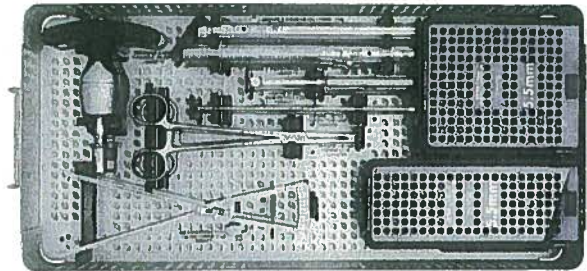

Reline 5.5m Cross Connector Implant Tray

MATERIAL DESCRIPTION	MATERIAL NUMBER	QTY
Reline X-Link T-handle, 40 in-lb	10000770	1
Reline Measurement Tool, Cross Connector	10000771	1
Reline Holder, Cross Connector	10000708	2
Reline Bender 2, Fixed Cross Connector	10000713	1
Reline Bender 1, Fixed Cross Connector	10000712	1
Reline Center Guide, Low-Profile Adj.	10000711	1
Reline Driver, Cross Connector Cam	10000709	1
Reline Fixed X-Con, 20mm 5.5mm Rod	10055320	1
Reline Fixed X-Con, 22.5mm 5.5mm Rod	10055322	1
Reline Fixed X-Con, 25mm 5.5mm Rod	10055325	1
Reline Fixed X-Con, 27.5mm 5.5mm Rod	10055327	1
Reline Fixed X-Con, 30mm 5.5mm Rod	10055330	1
Reline Fixed X-Con, 32.5mm 5.5mm Rod	10055332	1
Reline Fixed X-Con, 35mm 5.5mm Rod	10055335	1
Reline LP Adj. X-Con, 30-35mm 5.5mm Rod	10055430	1
Reline LP Adj. X-Con, 35-42mm 5.5mm Rod	10055435	1
Reline LP Adj. X-Con, 40-50mm 5.5mm Rod	10055440	1
Reline LP Adj. X-Con, 45-65mm 5.5mm Rod	10055445	2

RELINE™ SYSTEM – OPEN

OPEN SYSTEM | MAS® SYSTEM

RELINE 6.0mm CROSS CONNECTOR IMPLANT TRAY

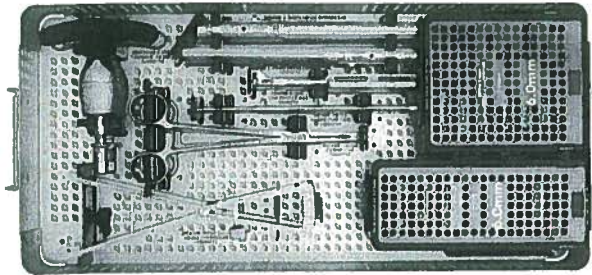

Reline 6.0mm Cross Connector Implant Tray

MATERIAL DESCRIPTION	MATERIAL NUMBER	QTY
NuVasive® X-Link T-handle, 40 in-lb	10000770	1
Reline Measurement Tool, Cross Connector	10000771	1
Reline Holder, Cross Connector	10000708	2
Reline Bender 2, Fixed Cross Connector	10000713	1
Reline Bender 1, Fixed Cross Connector	10000712	1
Reline Center Guide, Low-Profile Adj.	10000711	1
Reline Driver, Cross Connector Cam	10000709	1
Reline Fixed X-Con, 20mm 6.0mm Rod	10060320	1
Reline Fixed X-Con, 22.5mm 6.0mm Rod	10060322	1
Reline Fixed X-Con, 25mm 6.0mm Rod	10060325	1
Reline Fixed X-Con, 27.5mm 6.0mm Rod	10060327	1
Reline Fixed X-Con, 30mm 6.0mm Rod	10060330	1
Reline Fixed X-Con, 32.5mm 6.0mm Rod	10060332	1
Reline Fixed X-Con, 35mm 6.0mm Rod	10060335	1
Reline LP Adj. X-Con, 25-30mm 6.0mm Rod	10060425	1
Reline LP Adj. X-Con, 30-35mm 6.0mm Rod	10060430	1
Reline LP Adj. X-Con, 35-42mm 6.0mm Rod	10060435	1
Reline LP Adj. X-Con, 40-50mm 6.0mm Rod	10060440	1
Reline LP Adj. X-Con, 45-65mm 6.0mm Rod	10060445	2
Reline LP Adj. X-Con, 55-80mm 6.0mm Rod	10060455	1

RELINE™ SYSTEM – OPEN

OPEN SYSTEM | MAS SYSTEM

RELINE EXTRA POLYAXIAL SCREW IMPLANT TRAY

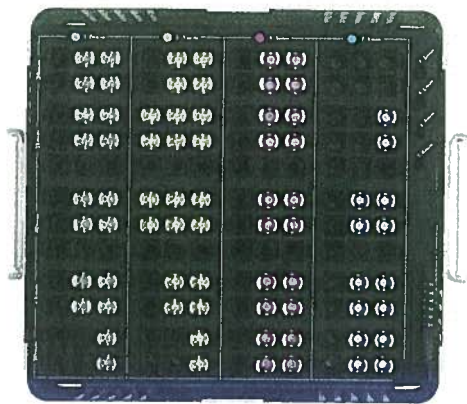

Reline Extra Polyaxial Screw Implant Tray

MATERIAL DESCRIPTION	MATERIAL NUMBER	QTY
Reline Screw, 5.0x30mm 2S Polyaxial	13015030	4
Reline Screw, 5.0x35mm 2S Polyaxial	13015035	4
Reline Screw, 5.0x40mm 2S Polyaxial	13015040	4
Reline Screw, 5.0x45mm 2S Polyaxial	13015045	4
Reline Screw, 5.0x50mm 2S Polyaxial	13015050	2
Reline Screw, 5.5x30mm 2S Polyaxial	13015530	4
Reline Screw, 5.5x35mm 2S Polyaxial	13015535	6
Reline Screw, 5.5x40mm 2S Polyaxial	13015540	6
Reline Screw, 5.5x45mm 2S Polyaxial	13015545	4
Reline Screw, 5.5x50mm 2S Polyaxial	13015550	2
Reline Screw, 6.5x30mm 2S Polyaxial	13016530	4
Reline Screw, 6.5x35mm 2S Polyaxial	13016535	4
Reline Screw, 6.5x40mm 2S Polyaxial	13016540	4
Reline Screw, 6.5x45mm 2S Polyaxial	13016545	4
Reline Screw, 6.5x50mm 2S Polyaxial	13016550	4
Reline Screw, 7.5x35mm 2S Polyaxial	13017535	2
Reline Screw, 7.5x40mm 2S Polyaxial	13017540	4
Reline Screw, 7.5x45mm 2S Polyaxial	13017545	4
Reline Screw, 7.5x50mm 2S Polyaxial	13017550	4

RELIRE™ SYSTEM – OPEN

OPEN SYSTEM | MAS® SYSTEM

RELIRE ILIAC IMPLANT TRAY

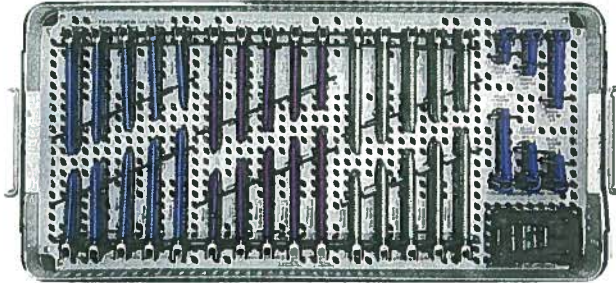

Relire Iliac Implant Tray – Top Level

MATERIAL DESCRIPTION	MATERIAL NUMBER	QTY
Relire Screw, 7.5x60mm 2S Iliac Closed	13037560	3
Relire Screw, 7.5x70mm 2S Iliac Closed	13037570	3
Relire Screw, 7.5x80mm 2S Iliac Closed	13037580	3
Relire Screw, 7.5x90mm 2S Iliac Closed	13037590	3
Relire Screw, 7.5x100mm 2S Iliac Closed	13037510	3
Relire Screw, 8.5x60mm 2S Iliac Closed	13038560	3
Relire Screw, 8.5x70mm 2S Iliac Closed	13038570	3
Relire Screw, 8.5x80mm 2S Iliac Closed	13038580	3
Relire Screw, 8.5x90mm 2S Iliac Closed	13038590	3
Relire Screw, 8.5x100mm 2S Iliac Closed	13038510	3
Relire Screw, 9.5x60mm 2S Iliac Closed	13039560	3
Relire Screw, 9.5x70mm 2S Iliac Closed	13039570	3
Relire Screw, 9.5x80mm 2S Iliac Closed	13039580	3
Relire Screw, 9.5x90mm 2S Iliac Closed	13039590	3
Relire Screw, 9.5x100mm 2S Iliac Closed	13039510	3

RELINE™ SYSTEM – OPEN

OPEN SYSTEM | MAS² SYSTEM

RELINE ILIAC IMPLANT TRAY (CONT.)

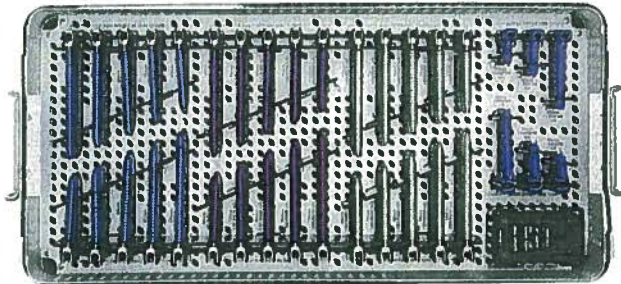

Reline Iliac Implant Tray – Top Level (Cont.)

MATERIAL DESCRIPTION	MATERIAL NUMBER	QTY
Reline Screw, 7.5x60mm 2S Polyaxial Iliac	13017560	3
Reline Screw, 7.5x70mm 2S Polyaxial Iliac	13017570	3
Reline Screw, 7.5x80mm 2S Polyaxial Iliac	13017580	3
Reline Screw, 7.5x90mm 2S Polyaxial Iliac	13017590	3
Reline Screw, 7.5x100mm 2S Polyaxial Iliac	13017510	3
Reline Screw, 8.5x60mm 2S Polyaxial Iliac	13018560	3
Reline Screw, 8.5x70mm 2S Polyaxial Iliac	13018570	3
Reline Screw, 8.5x80mm 2S Polyaxial Iliac	13018580	3
Reline Screw, 8.5x90mm 2S Polyaxial Iliac	13018590	3
Reline Screw, 8.5x100mm 2S Polyaxial Iliac	13018510	3
Reline Screw, 9.5x60mm 2S Polyaxial Iliac	13019560	3
Reline Screw, 9.5x70mm 2S Polyaxial Iliac	13019570	3
Reline Screw, 9.5x80mm 2S Polyaxial Iliac	13019580	3
Reline Screw, 9.5x90mm 2S Polyaxial Iliac	13019590	3
Reline Screw, 9.5x100mm 2S Polyaxial Iliac	13019510	3
Reline Closed Offset Connector, 20mm	11200120	3
Reline Closed Offset Connector, 30mm	11200130	3
Reline Closed Offset Connector, 60mm	11200160	3
Reline Open Offset Connector, 20mm	11200020	3
Reline Open Offset Connector, 30mm	11200030	3
Reline Open Offset Connector, 60mm	11200060	3
Reline Closed Tulip Lock Screw	13000000	8

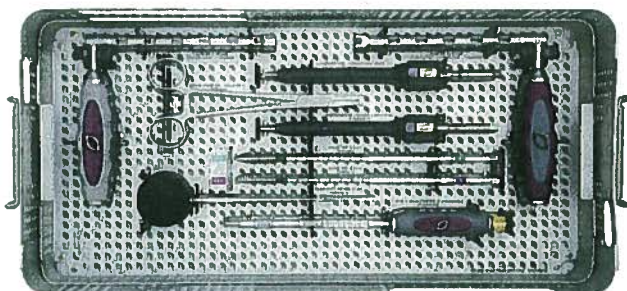

Reline Iliac Implant Tray – Bottom Level

MATERIAL DESCRIPTION	MATERIAL NUMBER	QTY
Reline Counter-torque, Closed Iliac	10000689	1
Reline Hook Inserter, Unilateral	10000693	1
Reline Gearshift Probe, Iliac	10000615	1
Reline Screwdriver, Closed Iliac Solid	D10000813	2
Reline Tap, 9.5mm Solid	10000635	1
Reline Tap, 8.5mm Solid	10000633	1
Reline Lock Screw Starter, Expandable	D10000745	1
Reline Counter-torque, Open Offset Connector	10000691	1

RELINE™ SYSTEM – OPEN

OPEN SYSTEM | MAS® SYSTEM

RELINE REDUCTION SCREW IMPLANT TRAY

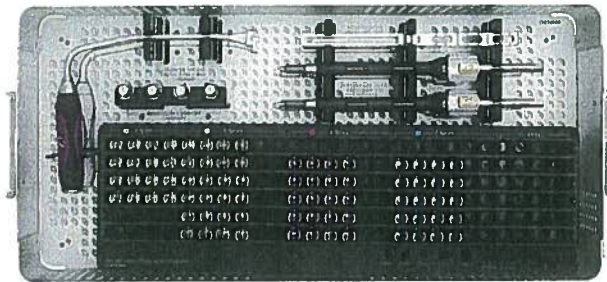

Reline Reduction Screw Implant Tray

MATERIAL DESCRIPTION	MATERIAL NUMBER	QTY
Reline Counter-torque, Reduction Screw	10000687	1
Reline Reduction Screw Cap, Open	10000299	4
Reline Screw, 4.5x30mm 2S Reduction	13024530	4
Reline Screw, 4.5x35mm 2S Reduction	13024535	4
Reline Screw, 4.5x40mm 2S Reduction	13024540	4
Reline Screw, 4.5x45mm 2S Reduction	13024545	4
Reline Screw, 5.5x30mm 2S Reduction	13025530	4
Reline Screw, 5.5x35mm 2S Reduction	13025535	4
Reline Screw, 5.5x40mm 2S Reduction	13025540	4
Reline Screw, 5.5x45mm 2S Reduction	13025545	4
Reline Screw, 5.5x50mm 2S Reduction	13025550	4
Reline Screw, 5.5x55mm 2S Reduction	13025555	4
Reline Screw, 6.5x35mm 2S Reduction	13026535	4
Reline Screw, 6.5x40mm 2S Reduction	13026540	4
Reline Screw, 6.5x45mm 2S Reduction	13026545	4
Reline Screw, 6.5x50mm 2S Reduction	13026550	4
Reline Screw, 6.5x55mm 2S Reduction	13026555	4
Reline Screw, 7.5x35mm 2S Reduction	13027535	4
Reline Screw, 7.5x40mm 2S Reduction	13027540	4
Reline Screw, 7.5x45mm 2S Reduction	13027545	4
Reline Screw, 7.5x50mm 2S Reduction	13027550	4
Reline Screw, 7.5x55mm 2S Reduction	13027555	4
Reline Break-off Tool, Reduction Tab	10000686	1
Reline Screwdriver, Solid Reduction	D10000832	2

RELINE SMALL POLYAXIAL IMPLANT TRAY

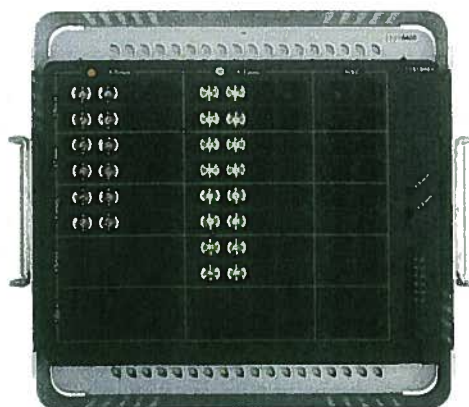

Reline Small Polyaxial Implant Tray

MATERIAL DESCRIPTION	MATERIAL NUMBER	QTY
Reline Screw, 4.0x30mm 2S Polyaxial	13014030	4
Reline Screw, 4.0x35mm 2S Polyaxial	13014035	4
Reline Screw, 4.0x40mm 2S Polyaxial	13014040	4
Reline Screw, 4.5x30mm 2S Polyaxial	13014530	4
Reline Screw, 4.5x35mm 2S Polyaxial	13014535	4
Reline Screw, 4.5x40mm 2S Polyaxial	13014540	4
Reline Screw, 4.5x45mm 2S Polyaxial	13014545	4

RELINE™ SYSTEM — OPEN

OPEN SYSTEM | MAS® SYSTEM

RELINE 8.5/9.5mm POLYAXIAL IMPLANT TRAY

Reline 8.5/9.5mm Polyaxial Implant Tray

MATERIAL DESCRIPTION	MATERIAL NUMBER	QTY
Reline Screw, 8.5x35mm 2S Polyaxial	13018535	4
Reline Screw, 8.5x40mm 2S Polyaxial	13018540	4
Reline Screw, 8.5x45mm 2S Polyaxial	13018545	4
Reline Screw, 8.5x50mm 2S Polyaxial	13018550	4
Reline Screw, 8.5x55mm 2S Polyaxial	13018555	4
Reline Screw, 9.5x35mm 2S Polyaxial	13019535	4
Reline Screw, 9.5x40mm 2S Polyaxial	13019540	4
Reline Screw, 9.5x45mm 2S Polyaxial	13019545	4
Reline Screw, 9.5x50mm 2S Polyaxial	13019550	4
Reline Screw, 9.5x55mm 2S Polyaxial	13019555	4

RELINE MONOAXIAL IMPLANT TRAY

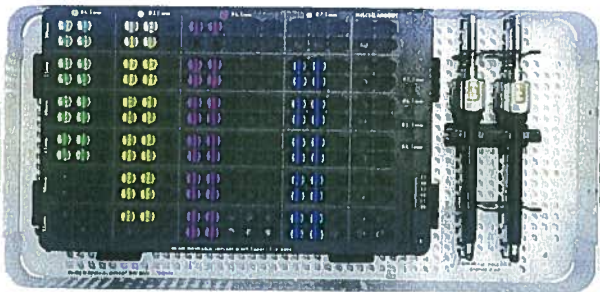

Reline Monoaxial Implant Tray

MATERIAL DESCRIPTION	MATERIAL NUMBER	QTY
Reline Screw, 4.5x30mm 2S Monoaxial	13084530	4
Reline Screw, 4.5x35mm 2S Monoaxial	13084535	4
Reline Screw, 4.5x40mm 2S Monoaxial	13084540	4
Reline Screw, 4.5x45mm 2S Monoaxial	13084545	4
Reline Screw, 5.5x30mm 2S Monoaxial	13085530	4
Reline Screw, 5.5x35mm 2S Monoaxial	13085535	4
Reline Screw, 5.5x40mm 2S Monoaxial	13085540	4
Reline Screw, 5.5x45mm 2S Monoaxial	13085545	4
Reline Screw, 5.5x50mm 2S Monoaxial	13085550	4
Reline Screw, 5.5x55mm 2S Monoaxial	13085555	2
Reline Screw, 6.5x30mm 2S Monoaxial	13086530	2
Reline Screw, 6.5x35mm 2S Monoaxial	13086535	4
Reline Screw, 6.5x40mm 2S Monoaxial	13086540	4
Reline Screw, 6.5x45mm 2S Monoaxial	13086545	4
Reline Screw, 6.5x50mm 2S Monoaxial	13086550	4
Reline Screw, 6.5x55mm 2S Monoaxial	13086555	4
Reline Screw, 7.5x35mm 2S Monoaxial	13087535	4
Reline Screw, 7.5x40mm 2S Monoaxial	13087540	4
Reline Screw, 7.5x45mm 2S Monoaxial	13087545	4
Reline Screw, 7.5x50mm 2S Monoaxial	13087550	4
Reline Screw, 7.5x55mm 2S Monoaxial	13087555	4
Reline Screwdriver, Fixed Solid	D10000818	2

RELINE™ FROM RUVASIVE®

RELINE™ SYSTEM – OPEN

OPEN SYSTEM | MAS® SYSTEM

RELINE PLS IMPLANT TRAY

Reline PLS Implant Tray

MATERIAL DESCRIPTION	MATERIAL NUMBER	QTY
Reline Screw, 4.5x30mm 2S PLS	13064530	4
Reline Screw, 4.5x35mm 2S PLS	13064535	4
Reline Screw, 4.5x40mm 2S PLS	13064540	4
Reline Screw, 4.5x45mm 2S PLS	13064545	4
Reline Screw, 5.5x30mm 2S PLS	13065530	4
Reline Screw, 5.5x35mm 2S PLS	13065535	4
Reline Screw, 5.5x40mm 2S PLS	13065540	4
Reline Screw, 5.5x45mm 2S PLS	13065545	4
Reline Screw, 5.5x50mm 2S PLS	13065550	4
Reline Screw, 6.5x30mm 2S PLS	13066530	2
Reline Screw, 6.5x35mm 2S PLS	13066535	4
Reline Screw, 6.5x40mm 2S PLS	13066540	4
Reline Screw, 6.5x45mm 2S PLS	13066545	4
Reline Screw, 6.5x50mm 2S PLS	13066550	4
Reline PLS Unlock Tool	10000775	1
Reline Counter-torque, Guide	10000552	1

RELINE UNIPLANAR IMPLANT TRAY

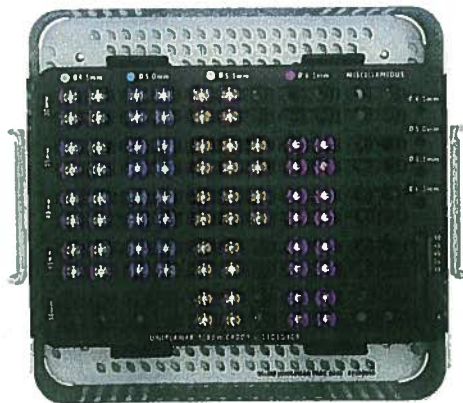

Reline Uniplanar Implant Tray

MATERIAL DESCRIPTION	MATERIAL NUMBER	QTY
Reline Screw, 4.5x30mm 2S Uniplanar	13044530	4
Reline Screw, 4.5x35mm 2S Uniplanar	13044535	4
Reline Screw, 4.5x40mm 2S Uniplanar	13044540	4
Reline Screw, 4.5x45mm 2S Uniplanar	13044545	4
Reline Screw, 5.0x30mm 2S Uniplanar	13045030	4
Reline Screw, 5.0x35mm 2S Uniplanar	13045035	4
Reline Screw, 5.0x40mm 2S Uniplanar	13045040	4
Reline Screw, 5.0x45mm 2S Uniplanar	13045045	4
Reline Screw, 5.5x30mm 2S Uniplanar	13045530	4
Reline Screw, 5.5x35mm 2S Uniplanar	13045535	6
Reline Screw, 5.5x40mm 2S Uniplanar	13045540	6
Reline Screw, 5.5x45mm 2S Uniplanar	13045545	4
Reline Screw, 5.5x50mm 2S Uniplanar	13045550	4
Reline Screw, 6.5x35mm 2S Uniplanar	13046535	4
Reline Screw, 6.5x40mm 2S Uniplanar	13046540	4
Reline Screw, 6.5x45mm 2S Uniplanar	13046545	4
Reline Screw, 6.5x50mm 2S Uniplanar	13046550	4

RELINE™ SYSTEM – OPEN

OPEN SYSTEM | MAS® SYSTEM

RELINE UNIPLANAR REDUCTION IMPLANT TRAY

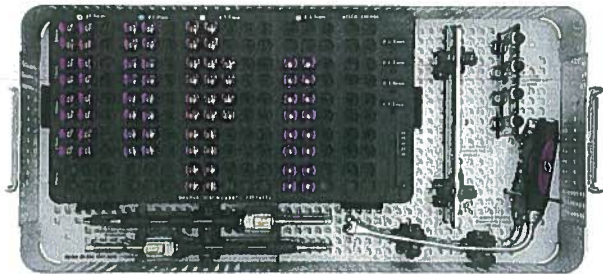

Reline Uniplanar Reduction Implant Tray

MATERIAL DESCRIPTION	MATERIAL NUMBER	QTY
Reline Screw, 4.5x30mm 2S Uni-Reduction	13054530	4
Reline Screw, 4.5x35mm 2S Uni-Reduction	13054535	4
Reline Screw, 4.5x40mm 2S Uni-Reduction	13054540	4
Reline Screw, 4.5x45mm 2S Uni-Reduction	13054545	4
Reline Screw, 5.0x30mm 2S Uni-Reduction	13055030	4
Reline Screw, 5.0x35mm 2S Uni-Reduction	13055035	4
Reline Screw, 5.0x40mm 2S Uni-Reduction	13055040	4
Reline Screw, 5.0x45mm 2S Uni-Reduction	13055045	4
Reline Screw, 5.5x30mm 2S Uni-Reduction	13055530	4
Reline Screw, 5.5x35mm 2S Uni-Reduction	13055535	6
Reline Screw, 5.5x40mm 2S Uni-Reduction	13055540	6
Reline Screw, 5.5x45mm 2S Uni-Reduction	13055545	4
Reline Screw, 5.5x50mm 2S Uni-Reduction	13055550	4
Reline Screw, 6.5x35mm 2S Uni-Reduction	13056535	4
Reline Screw, 6.5x40mm 2S Uni-Reduction	13056540	4
Reline Screw, 6.5x45mm 2S Uni-Reduction	13056545	4
Reline Screw, 6.5x50mm 2S Uni-Reduction	13056550	4
Reline Screw Driver, Solid Reduction	D10000832	2
Reline Counter-torque, Reduction Screw	10000687	1
Reline Break-off Tool, Reduction Tab	10000686	1
Reline Reduction Screw Cap, Open	10000299	4

RELINE™ SYSTEM – OPEN

OPEN SYSTEM | MAS™ SYSTEM

RELINE 5.5mm LONG ROD IMPLANT TRAY

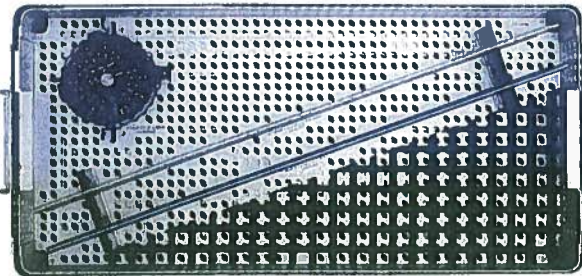
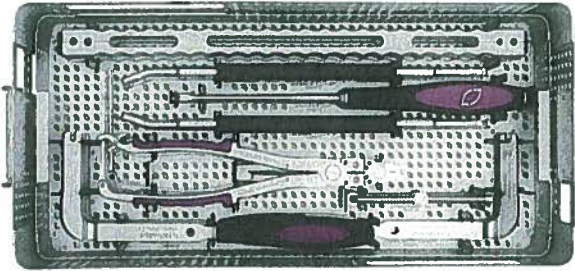

Reline 5.5mm Long Rod Implant Tray – Top Level

MATERIAL DESCRIPTION	MATERIAL NUMBER	QTY
Reline Plate Bender	10000730	2
Reline Sag Bender, 5.5mm Left	10000731	1
Reline Rod Pusher, Open	10000705	1
Reline Sag Bender, 5.5mm Right	10000732	1
Reline Gripper, 5.5mm Rod	10000703	2
Reline Coronal Bender Link	10000739	1
Reline Coronal Bender, 5.5mm Right	10000734	1
Reline Coronal Bender, 5.5mm Left	10000733	1

Reline 5.5mm Long Rod Implant Tray – Bottom Level

MATERIAL DESCRIPTION	MATERIAL NUMBER	QTY
Reline 5.5mm Lock Screw	13550000	20
Reline CoCr Rod, 5.5x500mm Straight	15455500	4
Reline Ti Rod, 5.5x500mm Straight	15355500	4

RELINE 6.0mm LONG ROD IMPLANT TRAY

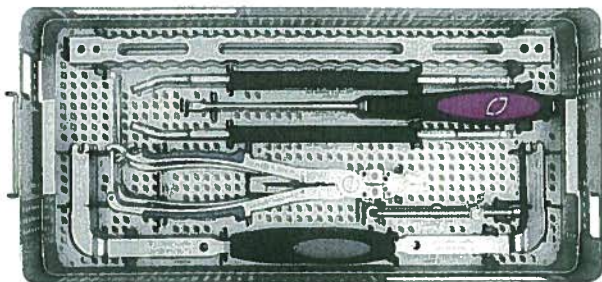

Reline 6.0mm Long Rod Implant Tray – Top Level

MATERIAL DESCRIPTION	MATERIAL NUMBER	QTY
Reline Plate Bender	10000730	2
Reline Sag Bender, 6.0mm Left	10000735	1
Reline Rod Pusher, Open	10000705	1
Reline Sag Bender, 6.0mm Right	10000736	1
Reline Gripper, 6.0mm Rod	10000704	2
Reline Coronal Bender Link	10000739	1
Reline Coronal Bender, 6.0mm Right	10000738	1
Reline Coronal Bender, 6.0mm Left	10000737	1

RELINE™ SYSTEM – OPEN

OPEN SYSTEM | MAS® SYSTEM

RELINE 6.0mm LONG ROD IMPLANT TRAY (CONT.)

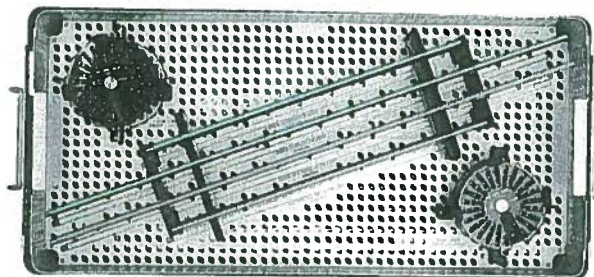

RELINE TAPERED ROD IMPLANT TRAY

Reline 6.0mm Long Rod Implant Tray – Bottom Level

MATERIAL DESCRIPTION	MATERIAL NUMBER	QTY
Reline 6.0mm Lock Screw	13600000	40
Reline Ti Rod, 6.0x300mm Straight	15360300	4
Reline Ti Rod, 6.0x500mm Straight	15360500	4
Reline CoCr Rod, 6.0x500mm Straight	15460500	4
Reline CoCr Rod, 6.0x300mm Straight	15460300	4

Reline Tapered Rod Implant Tray

MATERIAL DESCRIPTION	MATERIAL NUMBER	QTY
Reline Ti Rod, 5.5-5.0x300mm Tapered	15105300	3
Reline Ti Rod, 5.5-5.0x400mm Tapered	15105400	3
Reline Ti Rod, 5.5-5.0x500mm Tapered	15105500	3
Reline Ti Rod, 6.0-5.0x500mm Tapered	15165500	3
Reline CoCr Rod, 5.5-5.0x300mm Tapered	15205300	3
Reline CoCr Rod, 5.5-5.0x400mm Tapered	15205400	3
Reline CoCr Rod, 5.5-5.0x500mm Tapered	15205500	3
Reline CoCr Rod, 6.0-5.0x500mm Tapered	15265500	3

RELINE™ SYSTEM – OPEN

OPEN SYSTEM | MAS® SYSTEM

RELINE 5.5mm LORDOTIC COCR IMPLANT TRAY

Reline 5.5mm Lordotic CoCr Implant Tray

MATERIAL DESCRIPTION	MATERIAL NUMBER	QTY
Reline CoCr Rod, 5.5x30mm Lordotic	14455030	4
Reline CoCr Rod, 5.5x35mm Lordotic	14455035	4
Reline CoCr Rod, 5.5x40mm Lordotic	14455040	4
Reline CoCr Rod, 5.5x45mm Lordotic	14455045	4
Reline CoCr Rod, 5.5x50mm Lordotic	14455050	4
Reline CoCr Rod, 5.5x55mm Lordotic	14455055	4
Reline CoCr Rod, 5.5x60mm Lordotic	14455060	4
Reline CoCr Rod, 5.5x65mm Lordotic	14455065	4
Reline CoCr Rod, 5.5x70mm Lordotic	14455070	4
Reline CoCr Rod, 5.5x75mm Lordotic	14455075	4
Reline CoCr Rod, 5.5x80mm Lordotic	14455080	4
Reline CoCr Rod, 5.5x85mm Lordotic	14455085	4
Reline CoCr Rod, 5.5x90mm Lordotic	14455090	4
Reline CoCr Rod, 5.5x95mm Lordotic	14455095	4
Reline CoCr Rod, 5.5x100mm Lordotic	14455100	4
Reline CoCr Rod, 5.5x110mm Lordotic	14455110	4
Reline CoCr Rod, 5.5x120mm Lordotic	14455120	4

RELINE HOOK IMPLANT TRAY

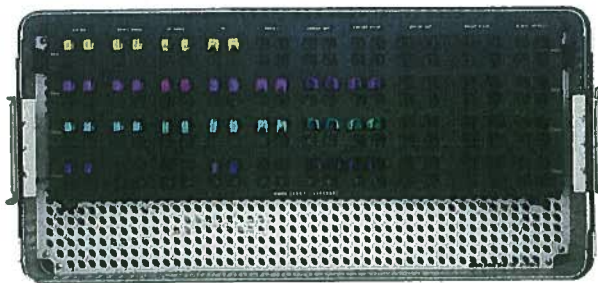

Reline Hook Implant Tray – Top Level

MATERIAL DESCRIPTION	MATERIAL NUMBER	QTY
Reline Lamina W, 6mm Hook	10200010	2
Reline Lamina W, 8mm Hook	10200012	2
Reline Lamina W, 10mm Hook	10200014	2
Reline Lamina W, 12mm Hook	10200016	2
Reline Lamina Down Angle W, 6mm Hook	10200026	2
Reline Lamina Down Angle W, 8mm Hook	10200028	2
Reline Lamina Down Angle W, 10mm Hook	10200030	2
Reline Lamina Up Angle W, 6mm Hook	10200110	2
Reline Lamina Up Angle W, 8mm Hook	10200112	2
Reline Lamina Up Angle W, 10mm Hook	10200114	2

RELINE™ SYSTEM – OPEN

OPEN SYSTEM | MAS® SYSTEM

RELINE HOOK IMPLANT TRAY (CONT.)

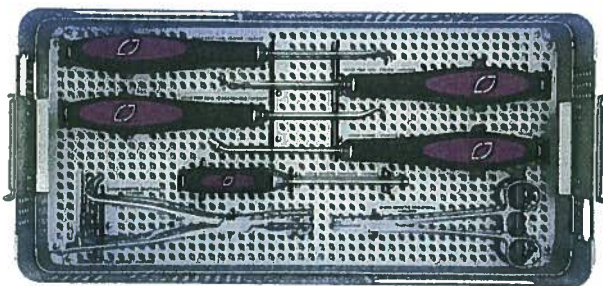
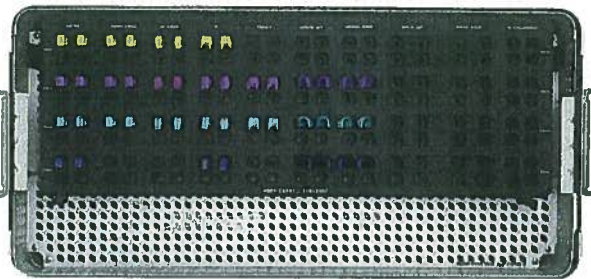

Reline Hook Implant Tray – Top Level (Cont.)

MATERIAL DESCRIPTION	MATERIAL NUMBER	QTY
Reline TP W, 8mm Hook	10200044	2
Reline TP W, 10mm Hook	10200046	2
Reline TP W, 12mm Hook	10200048	2
Reline Pedicle, 6mm Hook	10200302	2
Reline Pedicle, 8mm Hook	10200304	2
Reline Pedicle, 10mm Hook	10200306	2
Reline Angled Lf, 8mm Hook	10200604	2
Reline Angled Lf, 10mm Hook	10200606	2
Reline Angled Lf, 12mm Hook	10200608	2
Reline Angled Rt, 8mm Hook	10200612	2
Reline Angled Rt, 10mm Hook	10200614	2
Reline Angled Rt, 12mm Hook	10200616	2

Reline Hook Implant Tray – Bottom Level

MATERIAL DESCRIPTION	MATERIAL NUMBER	QTY
Reline Hook Prep Tool, Lamina	10000697	1
Reline Hook Prep Tool, Pedicle	10000698	1
Reline Hook Prep Tool, Trans Process	10000699	1
Reline Hook Pusher	10000695	1
Reline Hook Inserter, Threaded	10000692	1
Reline Hook Inserter, Bilateral	10000694	1
Reline Hook Inserter, Unilateral	10000693	1

RELINE ROD-ROD CONNECTOR IMPLANT TRAY

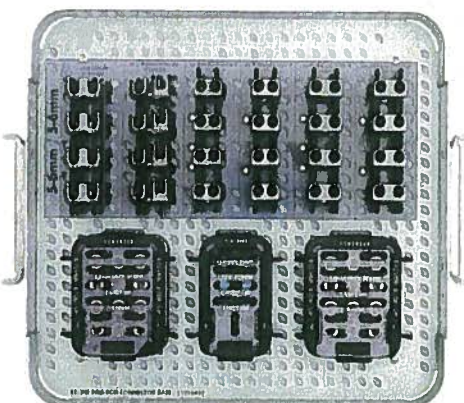

Reline Rod-Rod Connector Implant Tray

MATERIAL DESCRIPTION	MATERIAL NUMBER	QTY
Reline O-O Con M, 5.0/6.0mm Rod	11101255	4
Reline O-O Rotating Con, 5.0/6.0mm Rod	11103055	4
Reline 2H Parallel Con S, 5.0/6.0mm Rod	11106155	4
Reline 4H Parallel Con S, 5.0/6.0mm Rod	11107155	4
Reline 2H Parallel Con M, 5.0/6.0mm Rod	11106255	4
Reline 4H Parallel Con M, 5.0/6.0mm Rod	11107255	4
Reline 6.0mm Lock Screw	13550000	12
Reline Closed Tulip Lock Screw	13000000	8
Reline 6.0mm Lock Screw	13600000	12

RELINE™ SYSTEM – OPEN

OPEN SYSTEM | MAS® SYSTEM

RELINE DEROTATION INSTRUMENT TRAY

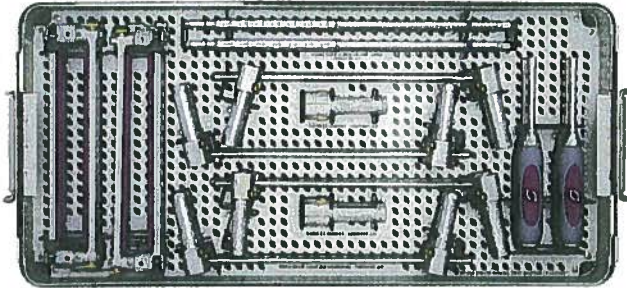

Reline Derotation Instrument Tray – Top Level

MATERIAL DESCRIPTION	MATERIAL NUMBER	QTY
Reline Derotation Clamp	10000772	2
Reline Final Lock Screw Driver, Long	10000750	2
Reline Derotator, Coupled Segmental	10000740	4
Reline Guide Extenders	10000543	2
Reline Derotation Driver	10000743	2

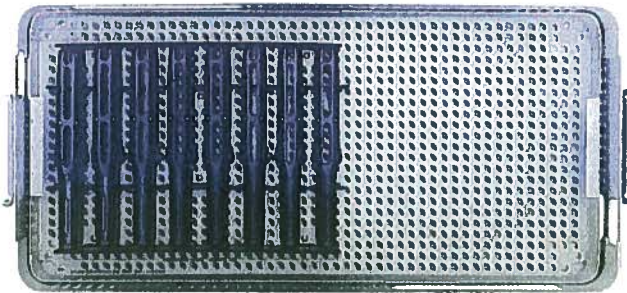

Reline Derotation Instrument Tray – Bottom Level

MATERIAL DESCRIPTION	MATERIAL NUMBER	QTY
Reline Derotation Tower	10000741	8

RELINE SILENCER REDUCER INSTRUMENT TRAY

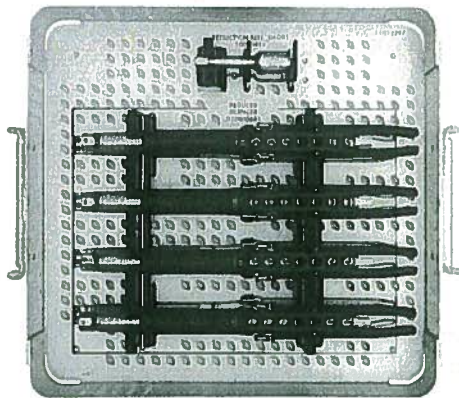

Reline Silencer Reducer Instrument Tray

MATERIAL DESCRIPTION	MATERIAL NUMBER	QTY
Reline Reduction Bell, Short	10000493	1
Reline Reducer, Silencer	D10000685	4

RELINE™ SYSTEM – OPEN

OPEN SYSTEM | MAS® SYSTEM

RELINE GATOR REDUCER INSTRUMENT TRAY

Reline Gator Reducer Instrument Tray

MATERIAL DESCRIPTION	MATERIAL NUMBER	QTY
Reline Reduction Bell, Short	10000493	1
Reline Reducer, Gator	D10000684	2

RELINE 5.5mm ROD GRIPPER INSTRUMENT TRAY

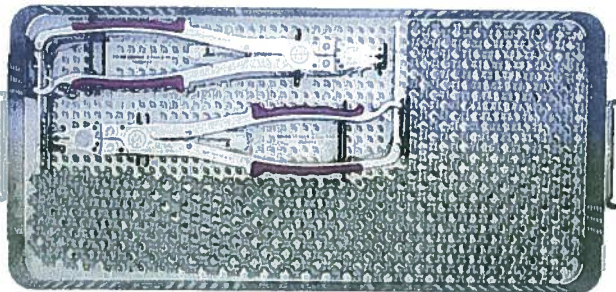

Reline 5.5mm Rod Gripper Instrument Tray

MATERIAL DESCRIPTION	MATERIAL NUMBER	QTY
Reline Gripper, 5.5mm Rod	10000703	2

RELINE™ SYSTEM – OPEN

OPEN SYSTEM | MAS® SYSTEM

RELINE ASF IMPLANT TRAY

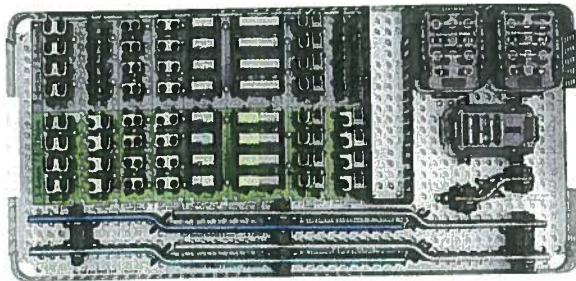

Reline ASF Implant Tray – Top Level

MATERIAL DESCRIPTION	MATERIAL NUMBER	QTY
Reline O-O Con M, 5.0/6.0mm Rod	11101255	4
Reline O-H Con M, 5.0/6.0mm Rod	11102255	4
Reline 2H Parallel Con S, 5.0/6.0mm Rod	11106155	4
Reline 2H Parallel Con M, 5.0/6.0mm Rod	11106255	4
Reline 2H In-Line Con, 5.0/6.0mm Rod	11108055	4
Reline 4H In-Line Con, 5.0/6.0mm Rod	11109055	4
Reline O-O Rotating Con, 5.0/6.0mm Rod	11103055	4
Reline O-H Rotating Con, 5.0/6.0mm Rod	11104055	4
Reline O-O Con M, 6.0/6.35mm Rod	11101260	4
Reline O-H Con M, 6.0/6.35mm Rod	11102260	4
Reline 2H Parallel Con S, 6.0/6.35mm Rod	11106160	4
Reline 2H Parallel Con M, 6.0/6.35mm Rod	11106260	4
Reline 2H In-Line Con, 6.0/6.35mm Rod	11108060	4
Reline 4H In-Line Con, 6.0/6.35mm Rod	11109060	4
Reline O-O Rotating Con, 6.0/6.35mm Rod	11103060	4
Reline O-H Rotating Con, 6.0/6.35mm Rod	11104060	4
Reline Lat Offset M Rod, 5.5 CoCr	18255002	4
Reline Lat Offset M Rod, 5.5 Ti	18155002	4
Reline Lat Offset M Rod, 6.0 CoCr	18260002	4
Reline Lat Offset M Rod, 6.0 Ti	18160002	4
Reline 5.5mm Lock Screw	13550000	12
Reline 6.0mm Lock Screw	13600000	12
Reline Closed Tulip Lock Screw	13000000	8
ASF Rod Template, Single Level	10000841	1



Reline ASF Implant Tray – Middle Level

MATERIAL DESCRIPTION	MATERIAL NUMBER	QTY
Reline Hook Insertor, Unilateral	10000693	1
Reline Chisel, 5.5mm	10000835	1
ASF Cobb	10000839	1
Reline Chisel, 6.35mm	10000836	1
Reline Rod-Rod Con., Threaded Insertor	10000834	1
ASF Rongeur	7459608	1

RELINE™ SYSTEM – OPEN

OPEN SYSTEM | MAS® SYSTEM

RELINE ASF IMPLANT TRAY (CONT.)

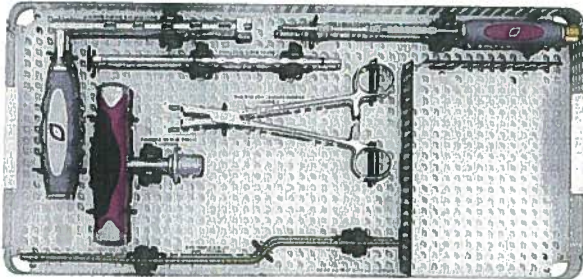

Reline ASF Implant Tray – Bottom Level

MATERIAL DESCRIPTION	MATERIAL NUMBER	QTY
Reline Counter-torque, Rod-Rod Con	10000690	1
Reline Final Lock Screw Driver	10000751	1
NuVasive® T-handle, 90 in-lb Torque	10000606	1
ASF Rod Template, Multilevel	10000840	1
Reline Lock Screw Starter, Expandable	D10000745	1
Reline Rod-Rod Con., Angled Inserter	10000837	1

3-COLUMN OSTEOTOMY INSTRUMENT TRAY

3-Column Osteotomy Instrument Tray – Top Level

MATERIAL DESCRIPTION	MATERIAL NUMBER	QTY
3CO Spoon Retractor, 15mm	10000863	2
3CO Spoon Retractor, 20mm	10000864	2
3CO Post Wall Impactor, 25mm	10000850	1
3CO Osteotome, 7mm	10000854	1
3CO Post Wall Impactor, 35mm	10000852	1
3CO Osteotome, 12mm	10000855	1
3CO Osteotome, Box, 7x7mm	10000872	1
3CO Osteotome, 17mm	10000856	1
3CO Osteotome, Box, 9x9mm	10000874	1

RELINE™ SYSTEM – OPEN

OPEN SYSTEM | MAS® SYSTEM

3-COLUMN OSTEOTOMY INSTRUMENT TRAY (CONT.)

3-Column Osteotomy Instrument Tray – Middle Level

MATERIAL DESCRIPTION	MATERIAL NUMBER	QTY
Ti 3CO Retractor, 10mm Square	8992207	1
Ti 3CO Retractor, 12mm Curved	8992203	1
3CO Wedge Caliper	10000859	1
3CO Cobb, Dual-ended	8992108	1
3CO Conical Shaver, 20°	10000860	1
3CO Conical Shaver, 30°	10000862	1

3-Column Osteotomy Instrument Tray – Bottom Level

MATERIAL DESCRIPTION	MATERIAL NUMBER	QTY
Ti 3CO Rack	8992999	2
3CO Retractor Tips, PSO Short, L	10000867	2
Ti 3CO Rack Tip, Left PSO	8992991	2
3CO Retractor Tips, PSO Short, R	10000868	2
Ti 3CO Rack Tip, Right PSO	8992992	2
3CO Rib Removal Tool	3230076	1
3CO Doyen, Left	3230074	1
3CO Doyen, Right	3230075	1

RELINE XT INSTRUMENT TRAY

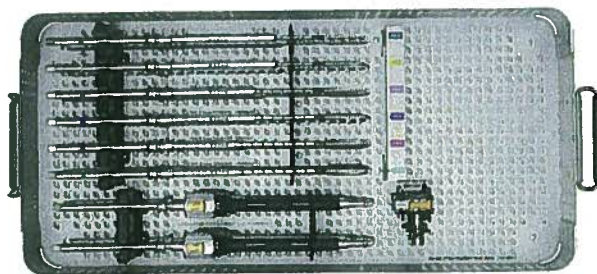

Reline XT Instrument Tray

MATERIAL DESCRIPTION	MATERIAL NUMBER	QTY
Reline Tap, 4.5mm Solid Ext	10000643	1
Reline Tap, 5.5mm Solid Ext	10000645	1
Reline Tap, 6.5mm Solid Ext	10000647	1
Reline Tap, 7.5mm Solid Ext	10000649	1
Reline Tap, 8.5mm Solid Ext	10000651	1
Reline Tap, 9.5mm Solid Ext	10000653	1
Reline Screwdriver, Poly Solid Ext	D10000822	2
Adaptor, Offset NVM5® Clip	8801349	1

RELINE™ SYSTEM – OPEN

OPEN SYSTEM | MAS® SYSTEM

ROD CUTTER INSTRUMENT TRAY

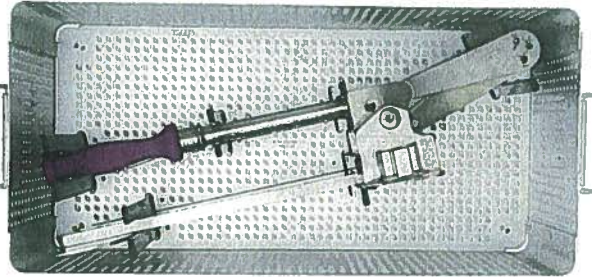

Rod Cutter Instrument Tray

MATERIAL DESCRIPTION	MATERIAL NUMBER	QTY
Reline Rod Cutter	10000768	1

RELINE™ SYSTEM – MAS®

OPEN SYSTEM | MAS® SYSTEM

RELINE MAS CORE INSTRUMENT TRAY 1

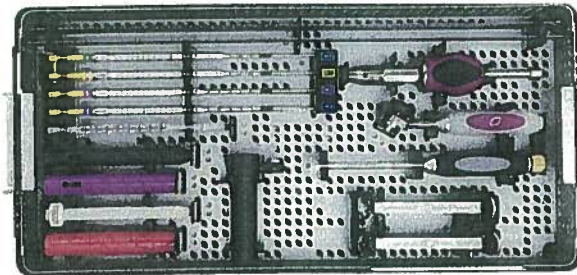

Reline MAS CORE Instrument Tray 1 – Top Level

MATERIAL DESCRIPTION	MATERIAL NUMBER	QTY
Generic NuVasive® Tray Lid	8801300	1
NIT K-wire, Bevel Tip	8801069	20
Universal Nitinol K-wire, Blunt Threaded	10000607	12
Reline Tap, 4.5mm Cannulated	10000425	1
Reline Tap, 5.5mm Cannulated	10000427	1
Reline Tap, 6.5mm Cannulated	10000429	1
Reline Tap, 7.5mm Cannulated	10000431	1
Reline Dilator, Initial	10000411	1
Reline Dilator, Tap	10000412	1
Reline Dilator, Screw	10000413	1
Reline Tap/Dilator Combo	10000422	1
Reline Dilator, Facet Tube	10000557	1
Reline Facet Tube	10000558	1
Reline Driver, K-wire	10000409	1
Reline Handle, Facet Tube	10000778	1
Reline Handle, Fascial Splitter	D10000423	1
Reline Holder, K-wire	D10000410	2
Reline Fascial Splitter Blade (disposable)*	10000795	

*Ordered separately

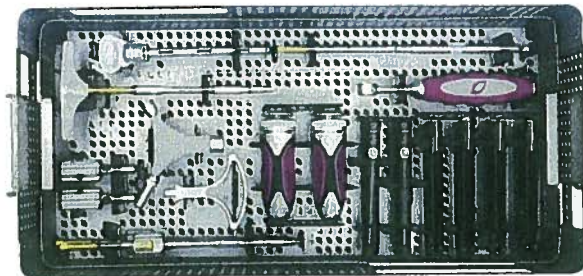

Reline MAS CORE Instrument Tray 1 – Middle Level

MATERIAL DESCRIPTION	MATERIAL NUMBER	QTY
Reline Removal Tool, Slip-on Guide	10000577	1
Reline Shank Adjuster, Cannulated	10000481	1
Reline Guide Tool, Acorn	10000549	2
Reline Tool, Combo	10000548	1
Reline Guide Adjuster	10000584	1
Reline Screwdriver, Poly Cannulated	10000800	2
NuVasive Handle, Straight Short Ratchet	10000602	2
Reline Tool, Guide Attachment	10000554	1
Reline Counter-torque, Open-Top Guide	10000767	1
Reline Guide, 1-Level, Open-Top	10000762	2
Reline Guide, 2-Level, Open-Top	10000546	2
Reline Guide, Standard	D10000332	8

RELINE™ SYSTEM – MAS®

OPEN SYSTEM | MAS® SYSTEM

RELINE MAS CORE INSTRUMENT TRAY 1 (CONT.)

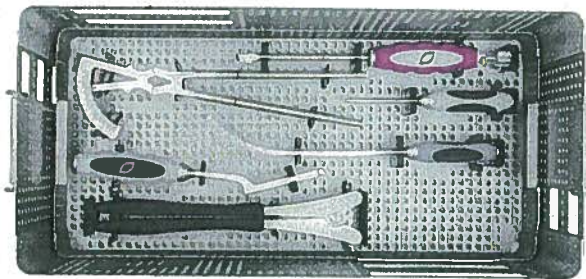

Reline MAS CORE Instrument Tray 1 – Bottom Level

MATERIAL DESCRIPTION	MATERIAL NUMBER	QTY
Reline Rod Measurement Tool	10000720	1
Reline Rod Inserter, Fixed Obtuse	D10000497	1
Reline French Bender	10000726	1
Reline Rod Inserter, Adjustable	D10000499	1
Reline Driver, Fixed Inserter	10000498	1
Reline Tissue Dissector, Curved	10000789	1

RELINE MAS CORE INSTRUMENT TRAY 2

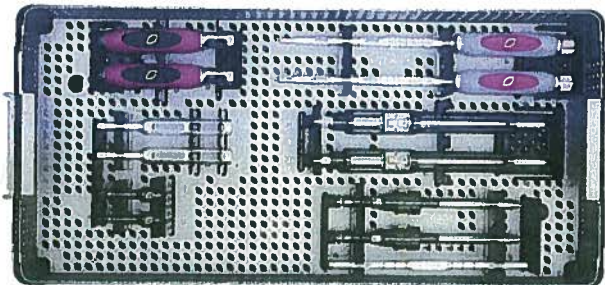

Reline MAS CORE Instrument Tray 2 – Top Level

MATERIAL DESCRIPTION	MATERIAL NUMBER	QTY
Reline Handle, Dual-ended, Straight	10000490	2
Reline Quarter Sq Attachment, Lock Screw	10000487	2
Reline Lock Screw Starter, Expandable	D10000745	2
Reline Reduction Bell	10000267	2
Reline Reducer, Bulldozer	10000483	2
Reline Reducer, Pile Driver	10000482	2
Reline Rod Pusher, Dual-ended	10000529	1

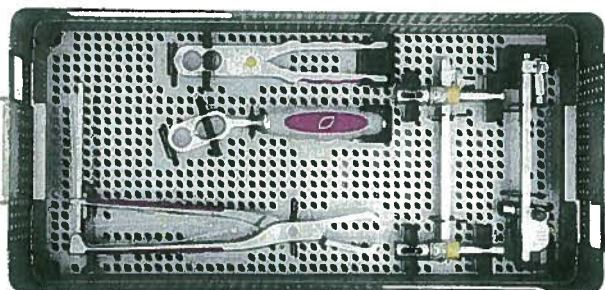

Reline MAS CORE Instrument Tray 2 – Middle Level

MATERIAL DESCRIPTION	MATERIAL NUMBER	QTY
Reline Guide Compressor, Hinged	10000533	1
Reline Compressor, Figure 8 Hinged	10000536	1
Reline Compressor, Figure 8 Upper	10000534	1
Reline C/D Rack, Bottom	10000562	1
Reline C/D Rack, Top	10000561	1

RELINE™ SYSTEM – MAS®

OPEN SYSTEM | MAS® SYSTEM

RELINE MAS CORE INSTRUMENT TRAY 2 (CONT.)

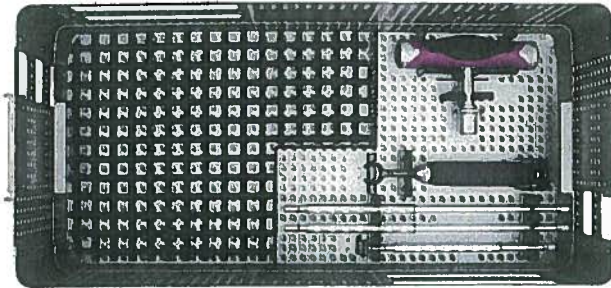

Reline MAS CORE Instrument Tray 2 – Bottom Level

MATERIAL DESCRIPTION	MATERIAL NUMBER	QTY
Reline Tray Pin Mat, MAS CORE Ins 2	11010453	1
NuVasive® T-handle, 90 in-lb Torque	10000606	1
Reline Counter-torque, Guide	10000552	1
Reline Final Lock Screw Driver, Long	10000750	2
Reline Final Lock Screw Driver, MAS	10000780	1

RELINE MAS CORE GUIDE BULLDOZER TRAY

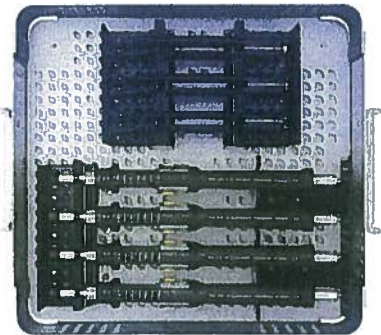

Reline MAS CORE Guide Bulldozer Tray

MATERIAL DESCRIPTION	MATERIAL NUMBER	QTY
Reline Reducer, Bulldozer	10000483	4
Reline Guide, Standard	D10000332	6

RELINE MAS CORE GUIDE PILE DRIVER TRAY

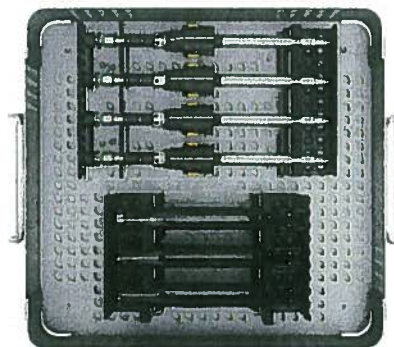

Reline MAS CORE Guide Pile Driver Tray

MATERIAL DESCRIPTION	MATERIAL NUMBER	QTY
Reline Reducer, Pile Driver	10000482	4
Reline Guide, Standard	D10000332	6

RELINE™ SYSTEM – MAS®

OPEN SYSTEM | MAS® SYSTEM

RELINE MAS CORE IMPLANT TRAY

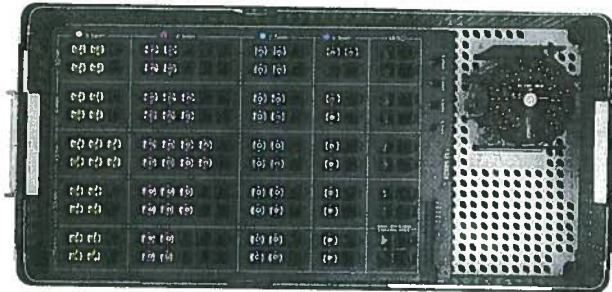

Reline MAS CORE Implant Tray – Top Level

MATERIAL DESCRIPTION	MATERIAL NUMBER	QTY
Reline MAS Polyaxial Screw Caddy	11010329	1
Reline Screw 5.5x35mm 2C Polyaxial	16015535	4
Reline Screw 5.5x40mm 2C Polyaxial	16015540	4
Reline Screw 5.5x45mm 2C Polyaxial	16015545	6
Reline Screw 5.5x50mm 2C Polyaxial	16015550	4
Reline Screw 5.5x55mm 2C Polyaxial	16015555	4
Reline Screw 6.5x35mm 2C Polyaxial	16016535	4
Reline Screw 6.5x40mm 2C Polyaxial	16016540	6
Reline Screw 6.5x45mm 2C Polyaxial	16016545	8
Reline Screw 6.5x50mm 2C Polyaxial	16016550	6
Reline Screw 6.5x55mm 2C Polyaxial	16016555	4
Reline Screw 7.5x35mm 2C Polyaxial	16017535	4
Reline Screw 7.5x40mm 2C Polyaxial	16017540	4
Reline Screw 7.5x45mm 2C Polyaxial	16017545	4
Reline Screw 7.5x50mm 2C Polyaxial	16017550	4
Reline Screw 7.5x55mm 2C Polyaxial	16017555	4
Reline Screw 8.5x35mm 2C Polyaxial	16018535	2
Reline Screw 8.5x40mm 2C Polyaxial	16018540	2
Reline Screw 8.5x45mm 2C Polyaxial	16018545	2
Reline Screw 8.5x50mm 2C Polyaxial	16018550	2
Reline Screw 8.5x55mm 2C Polyaxial	16018555	2
Reline 5.5mm Lock Screw Caddy	11010200	1
Reline 5.5mm Lock Screw	13550000	20

RELINE™ SYSTEM – MAS®

OPEN SYSTEM | MAS® SYSTEM

RELINE MAS CORE IMPLANT TRAY (CONT.)

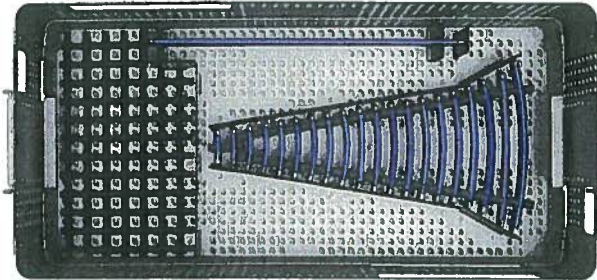

Reline MAS CORE Implant Tray – Bottom Level

MATERIAL DESCRIPTION	MATERIAL NUMBER	QTY
Reline Tray Pin Mat, MAS CORE Imp	11010454	1
Reline MAS Ti Rod, 5.5x25mm Lordotic	11355025	3
Reline MAS Ti Rod, 5.5x30mm Lordotic	11355030	3
Reline MAS Ti Rod, 5.5x35mm Lordotic	11355035	3
Reline MAS Ti Rod, 5.5x40mm Lordotic	11355040	3
Reline MAS Ti Rod, 5.5x45mm Lordotic	11355045	3
Reline MAS Ti Rod, 5.5x50mm Lordotic	11355050	3
Reline MAS Ti Rod, 5.5x55mm Lordotic	11355055	3
Reline MAS Ti Rod, 5.5x60mm Lordotic	11355060	3
Reline MAS Ti Rod, 5.5x65mm Lordotic	11355065	3
Reline MAS Ti Rod, 5.5x70mm Lordotic	11355070	3
Reline MAS Ti Rod, 5.5x75mm Lordotic	11355075	3
Reline MAS Ti Rod, 5.5x80mm Lordotic	11355080	3
Reline MAS Ti Rod, 5.5x85mm Lordotic	11355085	3
Reline MAS Ti Rod, 5.5x90mm Lordotic	11355090	3
Reline MAS Ti Rod, 5.5x95mm Lordotic	11355095	3
Reline MAS Ti Rod, 5.5x100mm Lordotic	11355100	3
Reline MAS Ti Rod, 5.5x110mm Lordotic	11355110	3
Reline MAS Ti Rod, 5.5x120mm Lordotic	11355120	3
Reline MAS Ti Rod, 5.5x140mm Lordotic	11355140	3
Reline MAS Ti Rod, 5.5x160mm Lordotic	11355160	3
Reline MAS Ti Rod, 5.5x300mm Straight	12355300	3

RELINE MAS CORE 5.5mm LONG CONSTRUCT TRAY

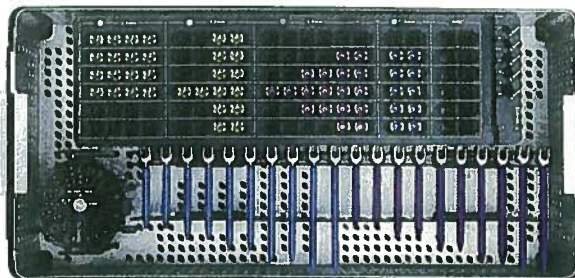

Reline MAS CORE 5.5mm Long Construct Tray – Top Level

MATERIAL DESCRIPTION	MATERIAL NUMBER	QTY
Reline 5.5mm Lock Screw Caddy	11010200	1
Reline MAS 5.5mm LC Poly Screw Caddy	11010318	1
Reline MAS 5.5mm LC Tray, Top	11010322	1
Reline 5.5mm Lock Screw	13550000	12
Reline Screw, 4.5x30mm 2C Polyaxial	16014530	4
Reline Screw, 4.5x35mm 2C Polyaxial	16014535	4
Reline Screw, 4.5x40mm 2C Polyaxial	16014540	4
Reline Screw, 4.5x45mm 2C Polyaxial	16014545	4
Reline Screw, 5.5x30mm 2C Polyaxial	16015530	2
Reline Screw, 5.5x35mm 2C Polyaxial	16015535	2

RELINE™ SYSTEM – MAS®

OPEN SYSTEM | MAS® SYSTEM

RELINE MAS CORE 5.5mm LONG CONSTRUCT TRAY (CONT.)

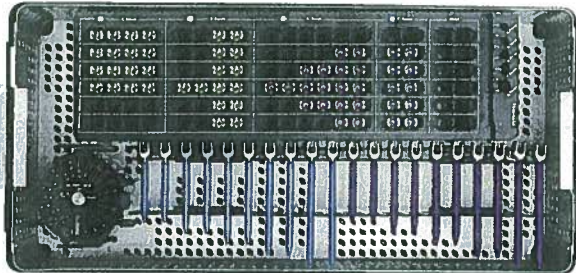

Reline MAS CORE 5.5mm Long Construct Tray – Top Level (Cont.)

MATERIAL DESCRIPTION	MATERIAL NUMBER	QTY
Reline Screw, 5.5x40mm 2C Polyaxial	16015540	2
Reline Screw, 5.5x45mm 2C Polyaxial	16015545	4
Reline Screw, 5.5x50mm 2C Polyaxial	16015550	2
Reline Screw, 5.5x55mm 2C Polyaxial	16015555	2
Reline Screw, 6.5x35mm 2C Polyaxial	16016535	2
Reline Screw, 6.5x40mm 2C Polyaxial	16016540	4
Reline Screw, 6.5x45mm 2C Polyaxial	16016545	6
Reline Screw, 6.5x50mm 2C Polyaxial	16016550	4
Reline Screw, 6.5x55mm 2C Polyaxial	16016555	2
Reline Screw, 7.5x35mm 2C Polyaxial	16017535	2
Reline Screw, 7.5x40mm 2C Polyaxial	16017540	2
Reline Screw, 7.5x45mm 2C Polyaxial	16017545	2
Reline Screw, 7.5x50mm 2C Polyaxial	16017550	2
Reline Screw, 7.5x55mm 2C Polyaxial	16017555	2
Reline Screw, 7.5x60mm 2C Polyaxial Iliac	16017560	2
Reline Screw, 7.5x70mm 2C Polyaxial Iliac	16017570	2
Reline Screw, 7.5x80mm 2C Polyaxial Iliac	16017580	2
Reline Screw, 7.5x90mm 2C Polyaxial Iliac	16017590	2
Reline Screw, 8.5x100mm 2C Polyaxial Iliac	16018510	2
Reline Screw, 8.5x60mm 2C Polyaxial Iliac	16018560	2
Reline Screw, 8.5x70mm 2C Polyaxial Iliac	16018570	2
Reline Screw, 8.5x80mm 2C Polyaxial Iliac	16018580	2
Reline Screw, 8.5x90mm 2C Polyaxial Iliac	16018590	2
Reline Screw, 7.5x100mm 2C Polyaxial Iliac	16017510	2

RELINE™ SYSTEM – MAS®

OPEN SYSTEM | MAS® SYSTEM

RELINE MAS CORE 5.5mm LONG CONSTRUCT TRAY (CONT.)

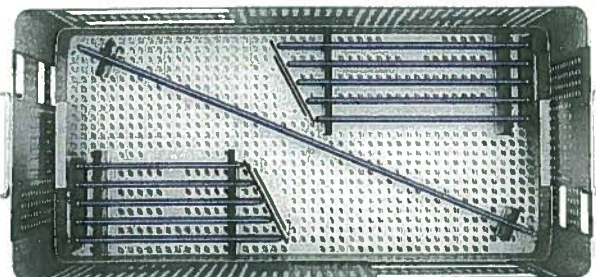

Reline MAS CORE 5.5mm Long Construct Tray – Middle Level

MATERIAL DESCRIPTION	MATERIAL NUMBER	QTY
Reline MAS Ti Rod, 5.5x160mm Straight	12355160	2
Reline MAS Ti Rod, 5.5x170mm Straight	12355170	2
Reline MAS Ti Rod, 5.5x180mm Straight	12355180	2
Reline MAS Ti Rod, 5.5x190mm Straight	12355190	2
Reline MAS Ti Rod, 5.5x200mm Straight	12355200	2
Reline MAS Ti Rod, 5.5x210mm Straight	12355210	2
Reline MAS Ti Rod, 5.5x220mm Straight	12355220	2
Reline MAS Ti Rod, 5.5x230mm Straight	12355230	2
Reline MAS Ti Rod, 5.5x240mm Straight	12355240	2
Reline MAS Ti Rod, 5.5x250mm Straight	12355250	2
Reline MAS Ti Rod, 5.5x500mm Straight	12355500	3

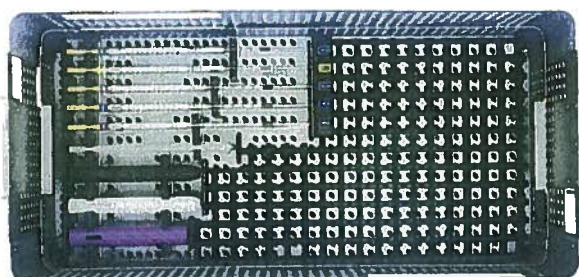

Reline MAS CORE 5.5mm Long Construct Tray – Bottom Level

MATERIAL DESCRIPTION	MATERIAL NUMBER	QTY
Reline Dilator, Initial	10000411	1
Reline Dilator, Tap	10000412	1
Reline Dilator, Screw	10000413	1
Reline Dilator, Large Tap	10000414	1
Reline Tap, 4.5mm Cannulated	10000425	1
Reline Tap, 5.5mm Cannulated	10000427	1
Reline Tap, 6.5mm Cannulated	10000429	1
Reline Tap, 7.5mm Cannulated	10000431	1
Reline Tap, 8.5mm Cannulated	10000433	1
Reline MAS 5.5mm LC Tray, Bottom	11010320	1
Reline Tray Pin Mat, MAS 5.5mm LC Imp	11010457	1

RELINE MAS CORE XT INSTRUMENT TRAY

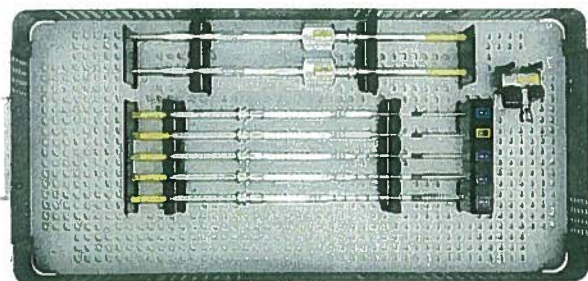

Reline MAS CORE XT Instrument Tray

MATERIAL DESCRIPTION	MATERIAL NUMBER	QTY
Reline Screwdriver, Poly Cannulated Ext	10000821	2
Reline Tap, 4.5mm Cannulated Ext	10000443	1
Reline Tap, 5.5mm Cannulated Ext	10000445	1
Reline Tap, 6.5mm Cannulated Ext	10000447	1
Reline Tap, 7.5mm Cannulated Ext	10000449	1
Reline Tap, 8.5mm Cannulated Ext	10000451	1
Adaptor, Offset NVM5® Clip	8801349	1

RELINE™ SYSTEM – MAS®

OPEN SYSTEM | MAS® SYSTEM

RELINE MAS REDUCTION INSTRUMENT TRAY 1

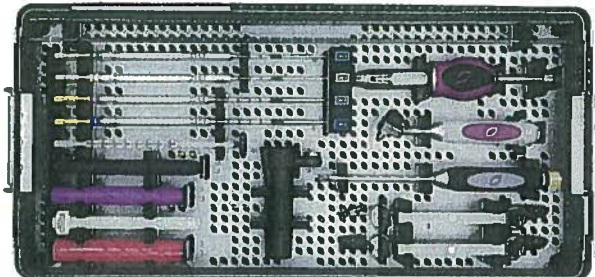

Reline MAS Reduction Instrument Tray 1 – Top Level

MATERIAL DESCRIPTION	MATERIAL NUMBER	QTY
NIT K-wire, Bevel Tip	8801069	20
Reline Driver, K-wire	10000409	1
Reline Dilator, Initial	10000411	1
Reline Tap/Dilator Combo	10000422	1
Reline Tap, 4.5mm Cannulated	10000425	1
Reline Tap, 5.5mm Cannulated	10000427	1
Reline Tap, 6.5mm Cannulated	10000429	1
Reline Tap, 7.5mm Cannulated	10000431	1
Reline Dilator, Facet Tube	10000557	1
Reline Facet Tube	10000558	1
Reline Dilator, Reduction Screw MAS	10000567	1
Reline Tap Dilator, Reduction Screw MAS	10000568	1
Universal Nitinol K-wire, Blunt Threaded	10000607	12
Reline Handle, Facet Tube	10000778	1
Reline Holder, K-wire	D10000410	2
Reline Handle, Fascial Splitter	D10000423	1

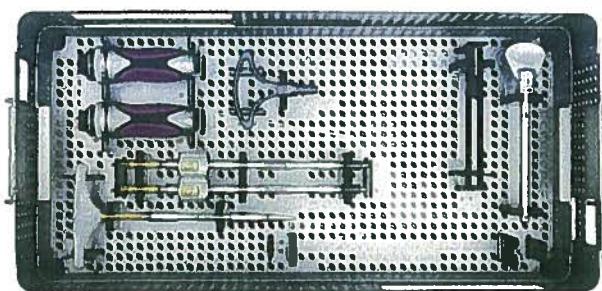

Reline MAS Reduction Instrument Tray 1 – Middle Level

MATERIAL DESCRIPTION	MATERIAL NUMBER	QTY
NuVasive Handle, Straight Short Ratchet	10000602	2
Reline Shank Adjuster, Cannulated	10000481	1
Reline Guide, Slip-on	10000547	1
Reline Tool, Guide Attachment	10000554	1
Reline Removal Tool, Slip-on Guide	10000577	1
Reline Extension Alignment Tool, MAS Reduction	10000781	1
Reline Screwdriver, Cannulated Reduction	10000831	2

RELINE™ SYSTEM – MAS®

OPEN SYSTEM | MAS® SYSTEM

RELINE MAS REDUCTION INSTRUMENT TRAY 1 (CONT.)

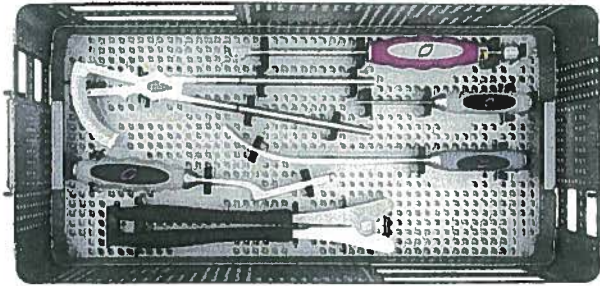

Reline MAS Reduction Instrument Tray 1 – Bottom Level

MATERIAL DESCRIPTION	MATERIAL NUMBER	QTY
Reline Driver, Fixed Inserter	10000498	1
Reline Rod Measurement Tool	10000720	1
Reline French Bender	10000726	1
Reline Tissue Dissector, Curved	10000789	1
Reline Rod Inserter, Fixed Obtuse	D10000497	1
Reline Rod Inserter, Adjustable	D10000499	1

RELINE MAS REDUCTION INSTRUMENT TRAY 2

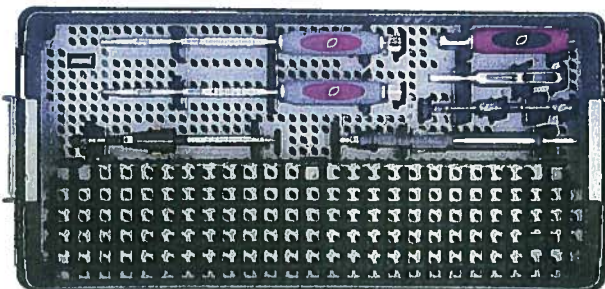

Reline MAS Reduction Instrument Tray 2 – Top Level

MATERIAL DESCRIPTION	MATERIAL NUMBER	QTY
Reline Lock Screw Starter, Expandable	D10000745	2
Reline Reducer, Pile Driver MAS Reduction	10000786	1
Reline Handle, Dual-ended, Straight	10000490	1
Reline Reduction Bell	10000267	1
Reline Quarter Sq Attachment, Lock Screw	10000487	2
Reline Reducer, Bulldozer MAS Reduction	10000777	1
Reline Tray Pin Mat, MAS Red Ins, 2-Top	11010455	1

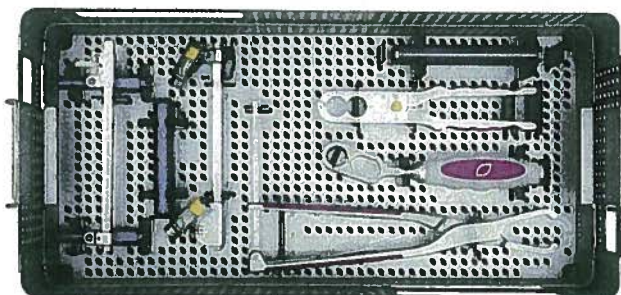

Reline MAS Reduction Instrument Tray 2 – Middle Level

MATERIAL DESCRIPTION	MATERIAL NUMBER	QTY
Reline C/D Rack, MAS Red Screw, Bottom	10000833	1
Reline C/D Rack, MAS Red Screw Sleeves	10000572	2
Reline C/D Rack, Top	10000561	1
Reline Guide Compressor, Hinged	10000533	1
Reline Counter-torque, Figure 8 Sleeves	10000569	2
Reline Compressor, Figure 8 Hinged	10000536	1
Reline Compressor, Figure 8 Upper	10000534	1

RELINE™ SYSTEM – MAS®

OPEN SYSTEM | MAS® SYSTEM

RELINE MAS REDUCTION INSTRUMENTS 2 (CONT.)

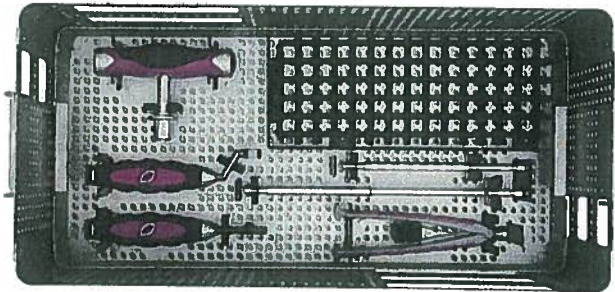

Reline MAS Reduction Instrument Tray 2 – Bottom Level

MATERIAL DESCRIPTION	MATERIAL NUMBER	QTY
NuVasive® T-handle, 90 in-lb Torque	10000606	1
Reline Counter-torque, Reduction Screw MAS	10000765	1
Reline Counter-torque, Guide	10000552	1
Reline Tray Pin Mat, MAS Red Ins 2, Bot	11010456	1
Reline Final Lock Screw Driver, MAS	10000780	1
Reline Final Lock Screw Driver, Long	10000750	2
Reline Splitter, Reduction Screw MAS	10000564	1

RELINE MAS REDUCTION IMPLANTS

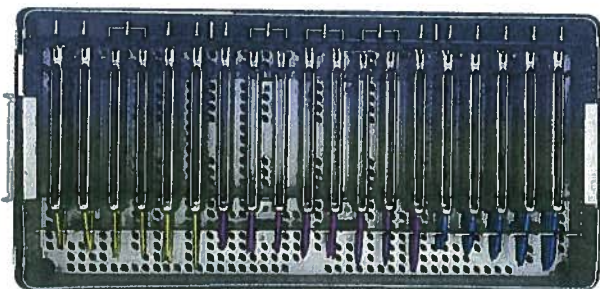

Reline MAS Reduction Implant Tray – Top Level

MATERIAL DESCRIPTION	MATERIAL NUMBER	QTY
Reline 5.5mm Lock Screw, Caddy	11010200	1
Reline 5.5mm Lock Screw	13550000	20
Reline Screw, 5.5x35mm 2C Reduction	16025535	4
Reline Screw, 5.5x40mm 2C Reduction	16025540	4
Reline Screw, 5.5x45mm 2C Reduction	16025545	6
Reline Screw, 5.5x50mm 2C Reduction	16025550	4
Reline Screw, 5.5x55mm 2C Reduction	16025555	4
Reline Screw, 6.5x35mm 2C Reduction	16026535	4
Reline Screw, 6.5x40mm 2C Reduction	16026540	6
Reline Screw, 6.5x45mm 2C Reduction	16026545	8
Reline Screw, 6.5x50mm 2C Reduction	16026550	6
Reline Screw, 6.5x55mm 2C Reduction	16026555	4
Reline Screw, 7.5x35mm 2C Reduction	16027535	4
Reline Screw, 7.5x40mm 2C Reduction	16027540	4
Reline Screw, 7.5x45mm 2C Reduction	16027545	4
Reline Screw, 7.5x50mm 2C Reduction	16027550	4
Reline Screw, 7.5x55mm 2C Reduction	16027555	4

RELINE™ SYSTEM – MAS®

OPEN SYSTEM | MAS® SYSTEM

RELINE MAS REDUCTION IMPLANT TRAY (CONT.)

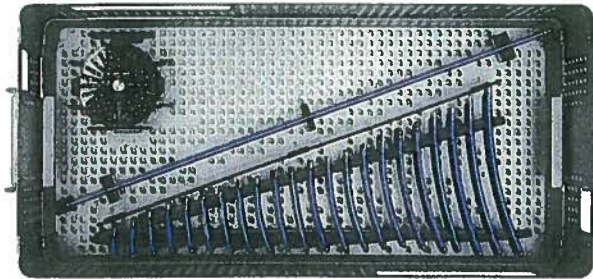

Reline MAS Reduction Implant Tray – Bottom Level

MATERIAL DESCRIPTION	MATERIAL NUMBER	QTY
Reline MAS Ti Rod, 5.5x25mm Lordotic	11355025	3
Reline MAS Ti Rod, 5.5x30mm Lordotic	11355030	3
Reline MAS Ti Rod, 5.5x35mm Lordotic	11355035	3
Reline MAS Ti Rod, 5.5x40mm Lordotic	11355040	3
Reline MAS Ti Rod, 5.5x45mm Lordotic	11355045	3
Reline MAS Ti Rod, 5.5x50mm Lordotic	11355050	3
Reline MAS Ti Rod, 5.5x55mm Lordotic	11355055	3
Reline MAS Ti Rod, 5.5x60mm Lordotic	11355060	3
Reline MAS Ti Rod, 5.5x65mm Lordotic	11355065	3
Reline MAS Ti Rod, 5.5x70mm Lordotic	11355070	3
Reline MAS Ti Rod, 5.5x75mm Lordotic	11355075	3
Reline MAS Ti Rod, 5.5x80mm Lordotic	11355080	3
Reline MAS Ti Rod, 5.5x85mm Lordotic	11355085	3
Reline MAS Ti Rod, 5.5x90mm Lordotic	11355090	3
Reline MAS Ti Rod, 5.5x95mm Lordotic	11355095	3
Reline MAS Ti Rod, 5.5x100mm Lordotic	11355100	3
Reline MAS Ti Rod, 5.5x110mm Lordotic	11355110	3
Reline MAS Ti Rod, 5.5x120mm Lordotic	11355120	3
Reline MAS Ti Rod, 5.5x130mm Lordotic	11355130	3
Reline MAS Ti Rod, 5.5x140mm Lordotic	11355140	3
Reline MAS Ti Rod, 5.5x150mm Lordotic	11355150	3
Reline MAS Ti Rod, 5.5x160mm Lordotic	11355160	3
Reline MAS Ti Rod, 5.5x500mm Straight	12355500	3

RELINE MAS REDUCTION 4.5mm IMPLANT TRAY

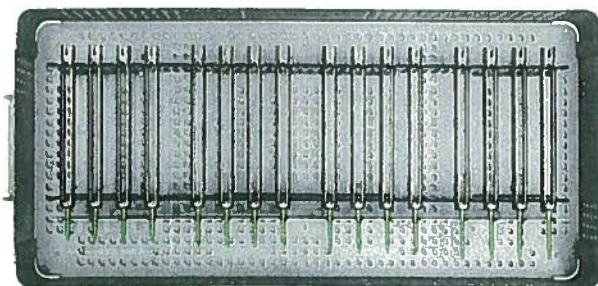

Reline MAS Reduction 4.5mm Implant Tray

MATERIAL DESCRIPTION	MATERIAL NUMBER	QTY
Reline Screw, 4.5x30mm 2C Reduction	16024530	4
Reline Screw, 4.5x35mm 2C Reduction	16024535	4
Reline Screw, 4.5x40mm 2C Reduction	16024540	4
Reline Screw, 4.5x45mm 2C Reduction	16024545	4

RELINE™ SYSTEM – MAS®

OPEN SYSTEM | MAS® SYSTEM

RELINE MAS REDUCTION 8.5mm IMPLANT TRAY

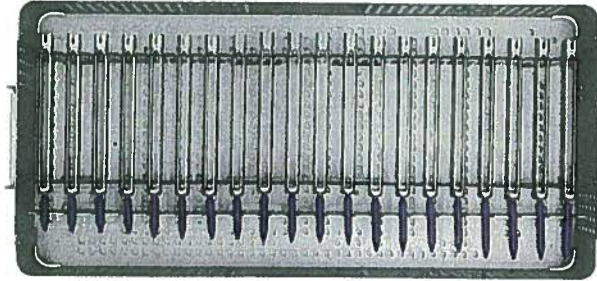

Reline MAS Reduction 8.5mm Implant Tray

MATERIAL DESCRIPTION	MATERIAL NUMBER	QTY
Reline Screw, 8.5x35mm 2C Reduction	16028535	4
Reline Screw, 8.5x40mm 2C Reduction	16028540	4
Reline Screw, 8.5x45mm 2C Reduction	16028545	4
Reline Screw, 8.5x50mm 2C Reduction	16028550	4
Reline Screw, 8.5x55mm 2C Reduction	16028555	4

INSTRUCTIONS FOR USE

DESCRIPTION

The *NuVasive® Reline™ System* consists of variety of screws, hooks, rods, lock screws, transverse connectors, rod-to-rod connectors and iliac connectors manufactured from Ti-6Al-4V ELI per ASTM F136 and ISO 5832-3, Grade 4 CP Ti per ASTM F67, or cobalt chromium per ASTM F1537.

INDICATIONS FOR USE

When used as a pedicle screw fixation system, the *NuVasive Reline System* is intended to provide immobilization and stabilization of spinal segments in skeletally mature patients as an adjunct to fusion in the treatment of the following acute and chronic instabilities or deformities of the posterior thoracic, lumbar, and sacral spine:

1. Degenerative disc disease (as defined by back pain of discogenic origin with degeneration of the disc confirmed by patient history and radiographic studies)
2. Degenerative spondylolisthesis with objective evidence of neurologic impairment
3. Fracture
4. Dislocation
5. Scoliosis
6. Kyphosis
7. Spinal tumor and/or
8. Failed previous fusion (pseudoarthrosis)

When used for posterior non-cervical screw fixation in pediatric patients, *NuVasive Reline System* is indicated as an adjunct to fusion to treat adolescent idiopathic scoliosis. Additionally the *NuVasive Reline System* is intended to treat pediatric patients diagnosed with the following conditions: spondylolisthesis / spondylolysis, and fracture caused by tumor and/or trauma. Pediatric pedicle screw fixation is limited to a posterior approach and is intended to be used with autograft and/or allograft.

The *NuVasive Reline System* is also indicated for the treatment of severe spondylolisthesis (Grades 3 and 4) of the L5-S1 vertebral joint in skeletally mature patients receiving fusion by autogenous bone graft, having the device fixed or attached to the lumbar and sacral spine (L3 to sacrum), with removal of the implants after attainment of a solid fusion.

When used as an anterolateral non-pedicle screw system in the thoracic and lumbar spine, the *NuVasive Reline System* is also intended for the following indications:

1. Degenerative disc disease (as defined by back pain of discogenic origin with degeneration of the disc confirmed by patient history and radiographic studies),
2. Spinal stenosis,
3. Spondylolisthesis,
4. Spinal deformities,
5. Fracture,
6. Pseudoarthrosis,
7. Tumor resection, and/or
8. Failed previous fusion.

CONTRAINDICATIONS

Contraindications include but are not limited to:

1. Infection, local to the operative site.
2. Signs of local inflammation.
3. Patients with known sensitivity to the materials implanted.
4. Patients who are unwilling to restrict activities or follow medical advice.
5. Patients with inadequate bone stock or quality.
6. Patients with physical or medical conditions that would prohibit beneficial surgical outcome.
7. Reusable or multiple uses.

POTENTIAL ADVERSE EVENTS AND COMPLICATIONS

As with any major surgical procedures, there are risks involved in orthopedic surgery. Infrequent operative and postoperative complications that may result in the need for additional surgeries include: early or late infection; damage to blood vessels, spinal cord or peripheral nerves; pulmonary emboli; loss of sensory and/or motor function; impotence; and permanent pain and/or deformity. Rarely, some complications may be fatal.

Potential risks identified with the use of this system, which may require additional surgery, include:

- Bending, fracture or loosening of implant component(s)
- Loss of fixation
- Nonunion or delayed union
- Fracture of the vertebra
- Neurological, vascular or visceral injury
- Metal sensitivity or allergic reaction to a foreign body
- Infection
- Decrease in bone density due to stress shielding
- Pain, discomfort or abnormal sensations due to the presence of the device
- Nerve damage due to surgical trauma
- Bursitis
- Dural leak
- Paralysis
- Death

WARNINGS, CAUTIONS AND PRECAUTIONS

The subject device is intended for use only as indicated.

The safety and effectiveness of pedicle screw spinal systems have been established only for spinal conditions with significant mechanical instability or deformity requiring fusion with instrumentation. These conditions are significant mechanical instability or deformity of the thoracic, lumbar, and sacral spine secondary to severe spondylolisthesis (grades 3 and 4) of the L5-S1 vertebra, degenerative spondylolisthesis with objective evidence of neurologic impairment, fracture, dislocation, scoliosis, kyphosis, spinal tumor, and failed previous fusion (pseudoarthrosis). The safety and effectiveness of these devices for any other conditions are unknown.

The implantation of pedicle screw spinal systems should be performed only by experienced spinal surgeons with specific training in the use of this pedicle screw spinal system because this is a technically demanding procedure presenting a risk of serious injury to the patient.

Benefit of spinal fusions utilizing any pedicle screw fixation system has not been adequately established in patients with stable spines.

The safety and effectiveness of this device has not been established for use as part of a growing rod construct. This device is only intended to be used when definitive fusion is being performed at all instrumented levels.

Correct selection of the implant is extremely important. The potential for success is increased by the selection of the proper size of the implant. While proper selection can minimize risks, the size and shape of human bones present limitations on the size and strength of implants. Metallic and internal fixation devices cannot withstand the activity levels and/or loads equal to those placed on normal, healthy bone. These devices are not designed to withstand the unsupported stress of full weight or load bearing alone.

These devices can break when subjected to the increased load associated with delayed union or nonunion. Internal fixation appliances are load-sharing devices that hold bony structures in alignment until healing occurs. If healing is delayed, or does not occur, the implant may eventually loosen, bend, or break. Loads on the device produced by load bearing and by the patient's activity level will dictate the longevity of the implant.

Caution must be taken due to potential patient sensitivity to materials. Do not implant in patients with known or suspected sensitivity to the aforementioned materials.

Corrosion of the implant can occur. Implanting metals and alloys in the human body subjects them to a constantly changing environment of salts, acids, and alkalis, which can cause corrosion. Placing dissimilar metals in contact with each other can accelerate the corrosion process, which in turn, can enhance fatigue fractures of implants. Consequently, every effort should be made to use compatible metals and alloys in conjunction with each other.

Care should be taken to insure that all components are ideally fixated prior to closure.

All implants should be used only with the appropriately designated instrument (Reference Surgical Technique).

Pivoting rod-rod connectors should be used in pairs (i.e., two per side).

INSTRUCTIONS FOR USE

Iliac screws have a single lead thread on the shaft and must be used with single lead taps to ensure proper purchase in bone.

Be careful when palpating the break point as the Tulip may be sharp.

The Silencer and Gator Reducers are not compatible with polyaxial reduction screws or uni-planar reduction screws and may damage the implant if used. Only the Matador Reducer and Rocker may be used with these reduction screws.

K-wire should be removed when screw has reached the posterior wall of the pedicle to avoid kink in tip.

Ensure the K-wire is not advancing as the path is created over the K-wire. Use lateral fluoroscopy to properly manage the K-wire during pedicle preparation to confirm proper placement and avoid anterior advancement of the K-wire.

All lock screws should be final-tightened with the Counter-torque and Torque T-handle. Do not final-tighten through compression instruments (e.g. C/D Rack and Figure 8 Compressor) in the set, as the rod may not be able to normalize to the tulip. Be cautious not to over compress or distract as you can loosen the screws in the spine and potentially pull out the screw.

The bulleted portion of the nose of the rod and the faceted portion of the rod (where the inserter locks down on the rod) must extend fully outside of the most inferior or most superior tulip on the construct. The set screw cannot be locked down on this unusable portion of the rod, as this may compromise the stability of the construct.

Cross connectors are designed specific to the rod diameter and cannot be used on the tapered section of tapered rods. If using cross connectors on tapered rods, only attach them on constant diameter rod sections.

All set screws should be final-tightened with the Counter-torque and Torque T-handle. Do not final-tighten through compression instruments in the set, as the rod may not be able to normalize to the tulip.

PATIENT EDUCATION: Preoperative instructions to the patient are essential. The patient should be made aware of the limitations of the implant and potential risks of the surgery. The patient should be instructed to limit postoperative activity, as this will reduce the risk of bent, broken or loose implant components. The patient must be made aware that implant components may bend, break or loosen even though restrictions in activity are followed.

SINGLE USE: Reuse of a single use device that has come in contact with blood, bone, tissue or other body fluids may lead to patient or user injury. Possible risks associated with reuse of a single use device include, but are not limited to, mechanical failure, material degradation, potential leachables, and transmission of infectious agents. Resterilization may result in damage or decreased performance.

MAGNETIC RESONANCE (MR) SAFETY: The *Reline System* has not been evaluated for safety and compatibility in the MR environment. The *Reline System* has not been tested for heating or migration in the MR environment.

COMPATIBILITY: Do not use *Reline System* with components of other systems than Armada System. Refer to the Armada System Instructions for Use for a list of the Armada System indications of use. Unless stated otherwise, NuVasive devices are not to be combined with the components of another system.

PREOPERATIVE WARNINGS

1. Only patients that meet the criteria described in the indications should be selected.
2. Patient condition and/or predispositions such as those addressed in the aforementioned contraindications should be avoided.
3. Care should be used in the handling and storage of the implants. The implants should not be scratched or damaged. Implants and instruments should be protected during storage and from corrosive environments.
4. All non-sterile parts should be cleaned and sterilized before use.
5. Devices should be inspected for damage prior to implantation.
6. Care should be used during surgical procedures to prevent damage to the device(s) and injury to the patient.

POSTOPERATIVE WARNINGS

During the postoperative phase it is of particular importance that the physician keeps the patient well informed of all procedures and treatments.

Damage to the weight-bearing structures can give rise to loosening of the components, dislocation and migration as well as to other complications. To ensure the earliest possible detection of such catalysts of device dysfunction, the devices must be checked periodically postoperatively, using appropriate radiographic techniques.

